

EFS 2000 ELECTRIC ACTUATORS

The EFS 2000 v4 series are electric quarter-turn spring-return actuators for closing and opening a valve in emergency conditions.

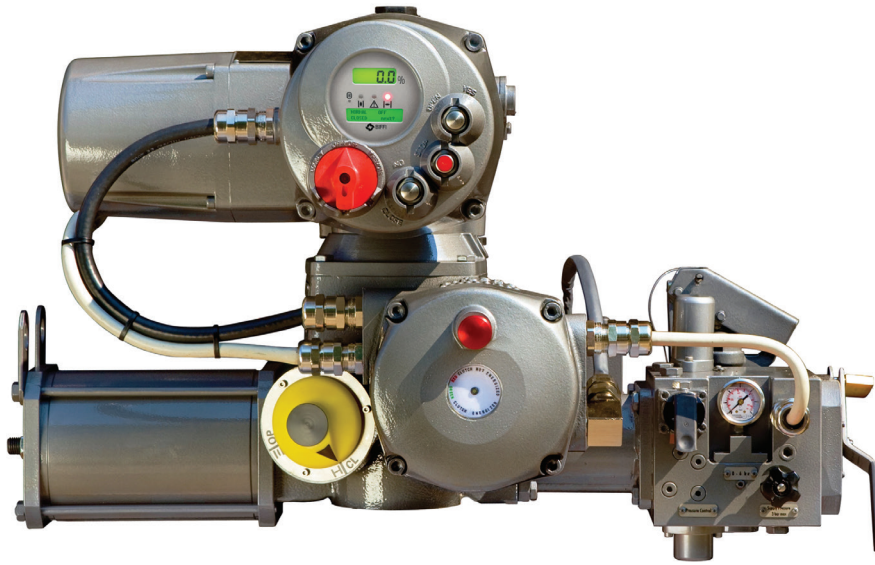

FEATURES

- Spring-return mechanism for moving the valve to the fail-safe position.
- Epicyclic gear reduction to increment the output torque of the electric actuator.
- Electro-magnetic clutch.
- Low pressure hydraulic control group for manual operation and operating speed regulation.
- Non-intrusive configuration.
- User-friendly push-button panel for operation, setting and diagnostics.
- Bluetooth® wireless connectivity.
- Advanced maintenance data and alarm reports.
- Valve condition monitoring.
- Configurable 'data logger' function for maintenance and diagnostic programs in recorder or event modes.
- User adjustable numeric and graphic displays with 8 language options.
- Double sealed terminal block.
- Digital contactless torque and position sensing.
- Advanced open bus communication protocols:
 - LonWorks®
 - Profibus DPV0, DPV1, redundant DPV1 and redundant DPV2
 - FOUNDATION™ Fieldbus
 - Modbus®
 - HART®
 - Wireless
- Certified for use in SIL 3 applications.

GENERAL APPLICATION

The EFS 2000 is available in eight sizes and is designed for on/off or inching operation of valves on safety critical applications in the oil and gas, process, and general industry sectors, where conventional pneumatic or hydraulic power supply to fail-safe actuators is unavailable.

APPROVALS

Waterproof: IP68 / IP68 (EN 60529)
 Explosionproof: Ex-d IIB T4 Gb (Gas) and
 c Ex tb IIIC T135°C Db (Dust)
 Safety integrity level
 (IEC 61508-1÷7:2010) - SIL3

TECHNICAL DATA

Power supply: 3 phase from 208 V to 690 V
 at 50/60 Hz
 1 phase from 110 V to 240 V
 at 50/60 Hz
 DC (direct current) from 24 V

Torque output: Spring starting torque
 up to 18000 Nm
 Spring ending torque
 up to 9000 Nm
 Electric mode starting torque
 up to 25500 Nm
 Electric mode ending torque
 up to 12500 Nm

Ambient temperature
 Standard range: -20°C to +60°C

EFS 2000 ELECTRIC ACTUATORS
 MAIN COMPONENT PARTS

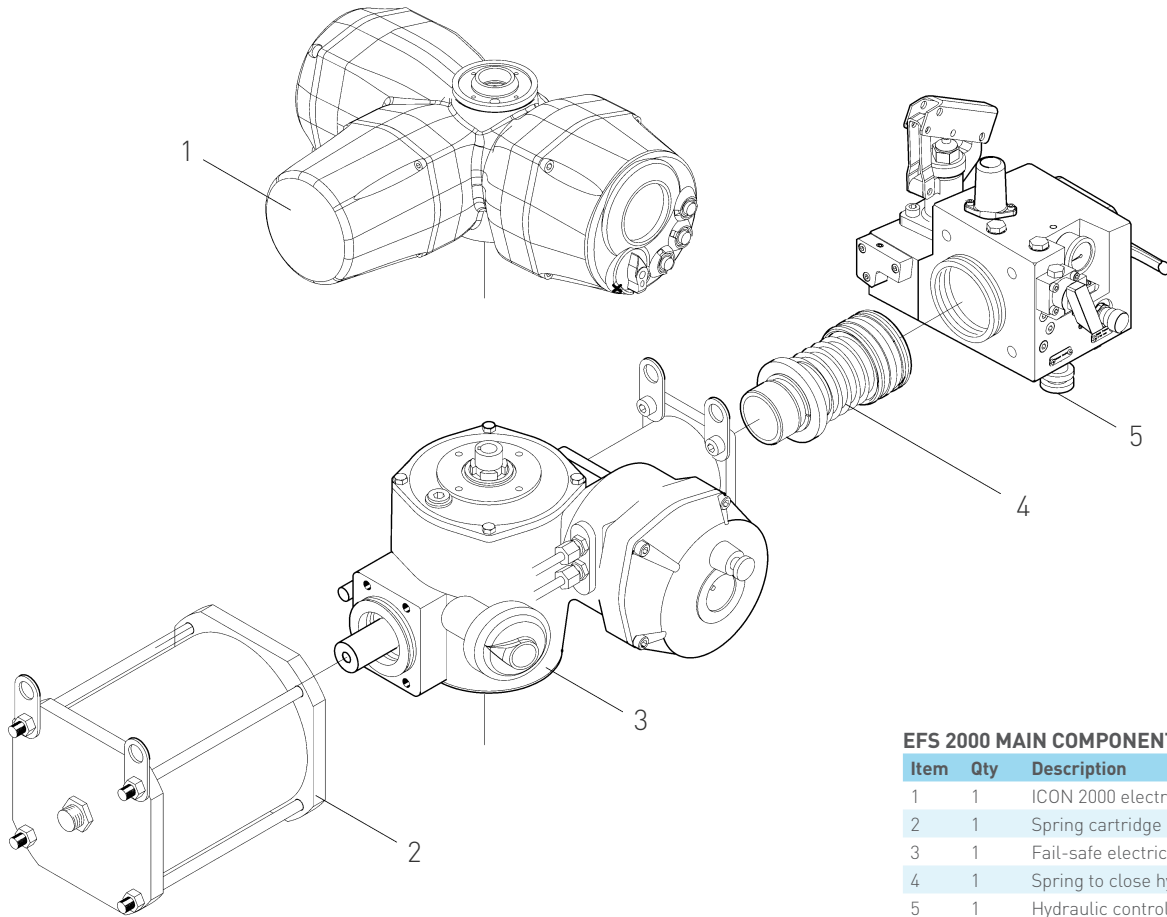

EFS 2000 MAIN COMPONENT PARTS

Item	Qty	Description
1	1	ICON 2000 electric actuator
2	1	Spring cartridge
3	1	Fail-safe electric actuator
4	1	Spring to close hydraulic actuator
5	1	Hydraulic control group

EFS 2000 ELECTRIC ACTUATORS

COMPONENT PARTS

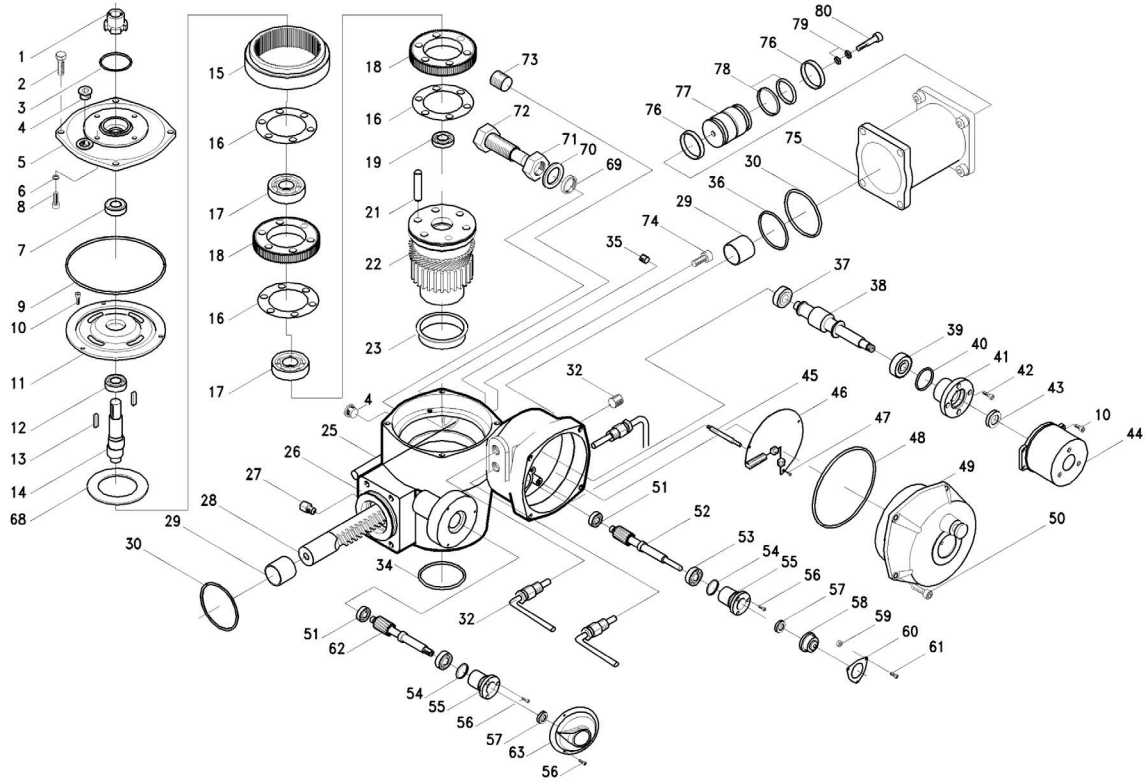

EFS 2000 COMPONENT PARTS

Item	Qty	Description	Material	Item	Qty	Description	Material	Item	Qty	Description	Material
1	1	Insert	Carbon steel	28	1	Rack	Alloy steel	54	2	O-ring	NBR rubber
2	4	Screw	Stainless steel	29	2	Bush	Steel-bronze-PTFE	55	2	Position transmitter shaft flange	Aluminum
3	1	O-ring	NBR rubber	30	2	O-ring	NBR rubber	56	9	Screw	Stainless steel
4	2	Oil plug	-	32	1	Wiring assembly	-	57	2	Seal ring	NBR rubber
5	1	Housing cover	Aluminum	34	1	O-ring	NBR rubber	58	1	Potentiometer assembly	-
6	4	Seal washer	-	35	1	Plug	Carbon steel	59	3	Column	Stainless steel
7	1	Seal ring	NBR rubber	36	1	O-ring	NBR rubber	60	1	Position transmitter shaft plate	Aluminum
8	4	Screw	Stainless steel	37	1	Bearing	Carbon steel	61	3	Screw	Stainless steel
9	1	O-ring	NBR rubber	38	1	Worm shaft	Carbon steel	62	1	Position shaft	Stainless steel
10	7	Screw	Stainless steel	39	1	Bearing	Carbon steel	63	1	Position indicator	Plastic
11	1	Worm well cover	Aluminum	40	1	O-ring	NBR rubber	68	1	Pin spacer	Carbon steel
12	1	Bearing	Carbon steel	41	1	Worm shaft flange	Aluminum	69	1	Seal ring	Carbon steel
13	2	Key	Carbon steel	42	4	Screw	Stainless steel	70	1	Washer	Carbon steel
14	1	Double eccentric shaft	Alloy steel	43	1	Seal ring	NBR rubber	71	1	Nut	Carbon steel
15	1	Worm wheel	Carbon steel	44	1	Clutch assembly	-	72	1	Adjusting screw	Carbon steel
16	3	Seal ring	Nylon	45	4	Column	Stainless steel	73	1	Screw	Carbon steel
17	2	Bearing	Carbon steel	46	1	EFS card	-	74	4	Screw	Carbon steel
18	2	Gear	Alloy steel	47	3	Screw	Stainless steel	76	1	Guide sliding	PTFE-graphite
19	1	Bearing	Carbon steel	48	1	O-ring	NBR rubber	77	1	Piston	Carbon steel
21	6	Pin	Alloy steel	49	1	Cover	Aluminum	78	1	Seal ring	NBR rubber
22	1	Splined bush	Alloy steel	50	4	Screw	Stainless steel	79	2	O-ring	NBR rubber
23	1	Bush washer	Bronze	51	2	Bearing	Carbon steel	80	1	Piston screw	Carbon steel
25	1	Lever assembly	-	52	1	Position transmitter shaft	-				
26	1	Housing	Aluminum	53	2	Bearing	NBR rubber				
27	1	Silencer	-								

EFS 2000 ELECTRIC ACTUATORS

EFS 2000 STANDARD SPECIFICATIONS

NON-HAZARDOUS AND HAZARDOUS AREA CERTIFICATIONS

ENCLOSURE / WEATHERPROOF STANDARDS (IEC)

Standards	Enclosure marking	Version	Temperature range		
			Up to 60 st/hr	> 60 st/hr	1-ph and DC
IEC EN60529	IP66 / IP68 (EN 60529)	Standard temperature	-20°C/+85°C	-20°C/+65°C	-20°C/+65°C
		Low temperature	-40°C/+65°C	-40°C/+65°C	-40°C/+65°C
		Extra low temperature	-60°C/+65°C	-60°C/+65°C	-60°C/+65°C

EUROPEAN STANDARDS HAZARDOUS AREAS (ATEX)

Standards	Enclosure marking		Version	Temperature range		
	Gas	Dust		Up to 60 st/hr	> 60 st/hr	1-ph and DC
ATEX (60079)	c Ex d IIB T4 Gb*	c Ex tb IIIC T135°C Db	Standard temperature	-45°C/+70°C	-45°C/+70°C	-45°C/+70°C
				-20°C/+60°C	-20°C/+60°C	-20°C/+60°C

NORTH AMERICAN STANDARDS HAZARDOUS AREAS (NEC / FM)

Standards	Enclosure marking	Version	Temperature range		
			Up to 60 st/hr	> 60 st/hr	1-ph and DC
FM	Class 1, Division 1, Group C, D	Standard temperature	-25°C/+60°C**	-25°C/+60°C**	-25°C/+60°C**

RUSSIAN STANDARDS HAZARDOUS AREAS (EAC COC)

Standards	Enclosure marking		Version	Temperature range		
	Gas	Dust		Up to 60 st/hr	> 60 st/hr	1-ph and DC
EAC CoC	c Ex d IIB T4 Gb*	c Ex tb IIIC T135°C Db	Standard temperature	-45°C/+70°C	-45°C/+70°C	-45°C/+70°C
				-20°C/+60°C	-20°C/+60°C	-20°C/+60°C

INDIA STANDARDS HAZARDOUS AREAS (CCOE)

Standards	Enclosure marking		Version	Temperature range		
	Gas	Dust		Up to 60 st/hr	> 60 st/hr	1-ph and DC
ATEX (60079-0)	Ex db IIB T4 Gb	Ex tb IIIC T135°C Db	Standard temperature	-20°C/+60°C	-20°C/+60°C	-20°C/+60°C

* With battery: add ia

** Applicable to model EFS with ICON 2000 010, 020

EFS 2000 ELECTRIC ACTUATORS

BASE VERSION FEATURES

BASE VERSION FEATURES

REMOTE CONTROLS

4 wires (OP, CL, Stop, C/latched)
3 wires (OP, CL, C/push-to-run or latched with instant reverse)
2 wires (NO contact to open or reverse)

Control voltage

24 V DC, internal supply
20 to 125 V DC, external supply
20 to 120 V AC, external supply

REMOTE OUTPUT CONTACTS

Status

Fully open
Fully closed
Position >=xx %
Position <=xx %
Closing
Opening
Motor running blinker
Local selected
Remote selected
Local stop active
PST active
Manual operation

Alarms

Motor over-temperature
Over-torque over torque in OP
Over-torque in CL
Valve jammed in OP
Valve jammed in CL
Valve jammed
Warnings
Low lithium battery (if present)
Mid-travel alarm in CL/OP
Mains-only AS8
EFS in manual mode
PST failed

Emergency shutdown (ESD)

Loss of main power
Local selector in OFF
By an emergency local pushbutton (mushroom type)
By remote hardwired command
Local reset

MONITOR RELAY

Loss of power
Loss of one phase
Electrical contactor failure
Loss of one phase
Local stop pushbutton pressed
Local selector switch in LOCAL/OFF
Internal temperature alarm
Position sensor failure
Hardware error
Motor temperature alarm

Torque alarm
Jammed valve
Mid-travel alarm
Speed sensor failure
Manual operation
ESD action
Low battery

INTELLIGENT PROTECTION

Automatic phase correction
Phase failure correction
Motor thermostat
Jammed valve protection
Anti-hammer protection
Instantaneous reversal protection

Warnings

Contacting failure
Maximum torque alarm
Torque alarm by-pass
High/low electronic temperature
Opto-coupled remote controls

VALVE MONITORING

TORQUE PROFILES

Breakout reference torque in opening
Peak running reference torque in opening
Ending reference torque in opening
Breakout torque in opening
Peak running torque in opening
Ending torque in opening
Breakout reference torque in closing
Peak running reference torque in closing
Ending reference torque in closing
Breakout torque in closing
Peak running torque in closing
Ending torque in closing
Date of the last 'set torque reference'
Date of last torque profile in opening
Date of last torque profile in closing

OPERATIONS

Opening time of the last stroke
Closing time of last stroke
Total contactor operations
Motor run time
Time out without electrical power
Utilization rate
Torque alarm number
Recent contactor operations
Recent motor run time
Recent time without electrical power
Recent utilization rate

ALARMS

Last 64 alarms and date
Last 64 warnings and date

MAINTENANCE DATA

Last maintenance date
Next maintenance date
Date of the last 'clear recent data log'
Start-up date

PST DATA

Last PST report
Next scheduled PST date
PST initial signature(sec/pos)
Last 100 PST profiles (sec/pos)

EFS DATA

Status
Clutch coil status
Manual/Auto selector status
Card temperature
Mushroom pushbutton status
Heater status

NAME PLATE

Serial number
Actuator size
Nominal torque
Actuator speed
Power supply
Motor rating
Motor duty
Motor poles
Motor type
Motor current
Test date
Wiring diagram
Enclosure
Certificate
Lubricant
HW version
SW version
Torque set-up in opening
Torque set-up in closing

VALVE DATA

Valve tag name
Valve serial number
Valve manufacturer
Break to open torque
Max. stem thrust
Valve coupling type

EFS 2000 ELECTRIC ACTUATORS

PERFORMANCE AND MOTOR DATA

EFS 2000 actuators can be supplied for single phase, three phase and DC power supplies. Performance and motor data is provided for the models indicated in the table below.

PERFORMANCE AND MOTOR DATA

Voltages	Power supply			Model							
	Single phase	Three phases	DC	EFS 10	EFS 20	EFS 40	EFS 80	EFS 160	EFS 320	EFS 480	EFS 960
24 V			✓	✓	✓	✓	✓	✓			
110 V	*			✓	✓	✓	✓	✓			
115 V	✓			✓	✓	✓	✓	✓			
120 V	✓			✓	✓	✓	✓	✓			
208 V		*		✓	✓	✓	✓	✓			
220 V	✓	*		✓	✓	✓	✓	✓			
230 V	✓	*		✓	✓	✓	✓	✓	✓	✓	*
240 V	✓	*		✓	✓	✓	✓	✓	✓	✓	*
280 V		*		✓	✓	✓	✓	✓	△	△	*
380 V		*		✓	✓	✓	✓	✓	△	△	*
400 V		✓		✓	✓	✓	✓	✓	△	△	*
415 V		*		✓	✓	✓	✓	✓	△	△	*
440 V		*		✓	✓	✓	✓	✓	△	△	*
460 V		*		✓	✓	✓	✓	✓	△	△	*
480 V		*		✓	✓	✓	✓	✓	△	△	*
500 V		*		✓	✓	✓	✓	✓	△	△	*
575 V		*		✓	✓	✓	✓	✓	△	△	*
690 V		*		✓	✓	✓	✓	✓	△	△	*

NOTES

- ✓ Available in the catalog
- * Available on request
- △ Available only with three phases

For all performance and motor data, the following notes apply:

Voltages

The tolerances on all voltage values shown are -10% / +10% (continuous), -15% / +10% (intermittent)

Nominal duties / duty ratings

Nominal duties are -5% / +5% according to IEC 60034-1

Nominal output power

Nominal output power (kW) is according to IEC 60034-1

Motors

All performance figures are based on Motor class H

Published values

The tolerances on published values are all according to IEC 60034-1

EFS 2000 ELECTRIC ACTUATORS

PERFORMANCE SINGLE PHASE SUPPLY 115 V / 50 Hz - SPRING TO CLOSE (CL) OR SPRING TO OPEN (OP)

ON/OFF S2-15', 60 STARTS/hr OR INCHING S2-30', 200 STARTS/hr

EFS Model	SET (Nm/lbf-ft) ^[1]	SST (Nm/lbf-ft) ^[2]	MST (Nm/lbf-ft) ^[3]	MET (Nm/lbf-ft) ^[4]	'ET (50Hz) sec/90° ^[5]	FST (sec/90°) ^[6]	Max. set actuator output torque (Nm/lbf-ft) ^[7,8]
EFS 10-CL(OP)/93-SR1 ^[9]	93/69	130/96	150/111	110/82	30 to 63	2 to 20	384/283
EFS 20-CL(OP)/225-SR1 ^[9]	225/166	300/222	350/259	275/203	22 to 84	2 to 20	602/444
EFS 40-CL(OP)/450-SR1 ^[9]	450/332	610/450	680/502	520/384	44 to 169	3 to 30	1206/890
EFS 80-CL(OP)/900-SR1 ^[9]	850/627	1150/849	1250/922	900/664	44 to 169	3 to 30	2091/1543
EFS 160-CL(OP)/1800-SR1 ^[9]	1800/1328	2800/2066	2800/2066	1800/1328	105 to 402	3 to 30	4791/3534

EFS Model	ICON model	Motor power (KW)	Motor nominal current (Inom) ^[10]	Motor max. current (Imax) ^[11]	Locked rotor current (Icc) ^[12]	'Eff. % nom'	Power factor	Absorbed power (Watt) ^[13]
EFS 10-CL(OP)/93-SR1 ^[9]	010/30-SR1	0.106	3.15	5.74	9.70	32.2	0.91	330
EFS 20-CL(OP)/225-SR1 ^[9]	010/90-SR1	0.184	5.75	11.17	24.00	30.9	0.90	595
EFS 40-CL(OP)/450-SR1 ^[9]	010/90-SR1	0.184	5.75	11.17	24.00	30.9	0.90	595
EFS 80-CL(OP)/900-SR1 ^[9]	010/110-SR1	0.184	5.75	11.17	24.00	30.9	0.90	595
EFS 160-CL(OP)/1800-SR1 ^[9]	010/110-SR1	0.184	5.75	11.17	24.00	30.9	0.90	595

NOTES

1. SET = Spring Ending Torque at 90° (end to close for CL - end to open for OP).
2. SST = Spring Starting Torque at 0° (start to close for CL - start to open for OP).
3. MST = Electric Mode Starting Torque at 90° (start to open for CL - start to close for OP).
4. MET = Electric Mode Ending Torque at 0° (end to open for CL - end to close for OP).
5. ET = Time for stroke with electric motor at 50Hz; multiply by 0.833 for 60Hz supply.
6. FST = Fail-Safe adjustable Time.
7. The max. set actuator output torque is referred to the open/close manoeuvre done with the electric motor set at 40% and the spring.
8. Under no circumstances should the motor set torque of 40% in the closing/opening direction be changed or the torque by-pass be removed.
9. Asynchronous motors with DELTA connections.
10. Inom - Actuator nominal current (at 40% set output torque) according to ISO 12590.
11. Imax - Actuator current at max. torque (100% set output torque) according to ISO 12590.
12. Icc - Actuator locked rotor current (current measured with motor energized and output drive locked) according to ISO 12590.
13. Absorbed power at nominal conditions (Watt).

EFS 2000 ELECTRIC ACTUATORS

PERFORMANCE SINGLE PHASE SUPPLY 120 V / 60 Hz - SPRING TO CLOSE (CL) OR SPRING TO OPEN (OP)

ON/OFF S2-15', 60 STARTS/hr OR INCHING S2-30', 200 STARTS/hr

EFS Model	SET (Nm/lbf-ft) ^[1]	SST (Nm/lbf-ft) ^[2]	MST (Nm/lbf-ft) ^[3]	MET (Nm/lbf-ft) ^[4]	'ET (50Hz) sec/90° ^[5]	FST (sec/90°) ^[6]	Max. set actuator output torque (Nm/lbf-ft) ^[7,8]
EFS 10-CL(OP)/93-SR1 ^[9]	93/69	130/96	150/111	110/82	30 to 63	2 to 20	384/283
EFS 20-CL(OP)/225-SR1 ^[9]	225/166	300/222	350/259	275/203	22 to 84	2 to 20	602/444
EFS 40-CL(OP)/450-SR1 ^[9]	450/332	610/450	680/502	520/384	44 to 169	3 to 30	1206/890
EFS 80-CL(OP)/900-SR1 ^[9]	850/627	1150/849	1250/922	900/664	44 to 169	3 to 30	2091/1543
EFS 160-CL(OP)/1800-SR1 ^[9]	1800/1328	2800/2066	2800/2066	1800/1328	105 to 402	3 to 30	4791/3534

EFS Model	ICON model	Motor power (KW)	Motor nominal current (Inom) ^[10]	Motor max. current (Imax) ^[11]	Locked rotor current (Icc) ^[12]	'Eff. % nom'	Power factor	Absorbed power (Watt) ^[13]
EFS 10-CL(OP)/93-SR1 ^[9]	010/30-SR1	0.127	3.00	5.50	9.30	38.8	0.91	328
EFS 20-CL(OP)/225-SR1 ^[9]	010/90-SR1	0.221	5.50	10.70	23.00	37.2	0.90	594
EFS 40-CL(OP)/450-SR1 ^[9]	010/90-SR1	0.221	5.50	10.70	23.00	37.2	0.90	594
EFS 80-CL(OP)/900-SR1 ^[9]	010/110-SR1	0.221	5.50	10.70	23.00	37.2	0.90	594
EFS 160-CL(OP)/1800-SR1 ^[9]	010/110-SR1	0.221	5.50	10.70	23.00	37.2	0.90	594

NOTES

1. SET = Spring Ending Torque at 90° (end to close for CL - end to open for OP).
2. SST = Spring Starting Torque at 0° (start to close for CL - start to open for OP).
3. MST = Electric Mode Starting Torque at 90° (start to open for CL - start to close for OP).
4. MET = Electric Mode Ending Torque at 0° (end to open for CL - end to close for OP).
5. ET = Time for stroke with electric motor at 50Hz; multiply by 0.833 for 60Hz supply.
6. FST = Fail-Safe adjustable Time.
7. The max. set actuator output torque is referred to the open/close manoeuvre done with the electric motor set at 40% and the spring.
8. Under no circumstances should the motor set torque of 40% in the closing/opening direction be changed or the torque by-pass be removed.
9. Asynchronous motors with DELTA connections.
10. Inom - Actuator nominal current (at 40% set output torque) according to ISO 12590.
11. Imax - Actuator current at max. torque (100% set output torque) according to ISO 12590.
12. Icc - Actuator locked rotor current (current measured with motor energized and output drive locked) according to ISO 12590.
13. Absorbed power at nominal conditions (Watt).

EFS 2000 ELECTRIC ACTUATORS

PERFORMANCE SINGLE PHASE SUPPLY 220 V / 50 Hz - SPRING TO CLOSE (CL) OR SPRING TO OPEN (OP)

ON/OFF S2-15', 60 STARTS/hr OR INCHING S2-30', 200 STARTS/hr

EFS Model	SET (Nm/lbf-ft) ^[1]	SST (Nm/lbf-ft) ^[2]	MST (Nm/lbf-ft) ^[3]	MET (Nm/lbf-ft) ^[4]	'ET (50Hz) sec/90° ^[5]	FST (sec/90°) ^[6]	Max. set actuator output torque (Nm/lbf-ft) ^[7,8]
EFS 10-CL(OP)/93-SR1 ^[9]	93/69	130/96	150/111	110/82	30 to 63	2 to 20	384/283
EFS 20-CL(OP)/225-SR1 ^[9]	225/166	300/222	350/259	275/203	22 to 84	2 to 20	602/444
EFS 40-CL(OP)/450-SR1 ^[9]	450/332	610/450	680/502	520/384	44 to 169	3 to 30	1206/890
EFS 80-CL(OP)/900-SR1 ^[9]	850/627	1150/849	1250/922	900/664	44 to 169	3 to 30	2091/1543
EFS 160-CL(OP)/1800-SR1 ^[9]	1800/1328	2800/2066	2800/2066	1800/1328	105 to 402	3 to 30	4791/3534
EFS 320-CL(OP)/3600-SR1 ^[9]	3600/2656	5400/3983	5400/3982	3600/2655	36 to 208	3 to 30	8685/6241
EFS 480-CL(OP)/4500-SR1 ^[9]	4500/3319	7800/5753	5800/4277	3600/2655	36 to 208	3 to 30	11085/8176

EFS Model	ICON model	Motor power (KW)	Motor nominal current (Inom) ^[10]	Motor max. current (Imax) ^[11]	Locked rotor current (Icc) ^[12]	'Eff. % nom'	Power factor	Absorbed power (Watt) ^[13]
EFS 10-CL(OP)/93-SR1 ^[9]	010/30-SR1	0.106	1.15	1.88	4.18	46.0	0.91	230
EFS 20-CL(OP)/225-SR1 ^[9]	010/90-SR1	0.184	3.35	5.75	12.02	27.8	0.90	662
EFS 40-CL(OP)/450-SR1 ^[9]	010/90-SR1	0.184	3.35	5.75	12.02	27.8	0.90	662
EFS 80-CL(OP)/900-SR1 ^[9]	010/110-SR1	0.184	3.35	5.75	12.02	27.8	0.90	662
EFS 160-CL(OP)/1800-SR1 ^[9]	010/110-SR1	0.184	3.35	5.75	12.02	27.8	0.90	662
EFS 320-CL(OP)/3600-SR1 ^[9]	020/240-SR1	0.80	5.08	9.14	15.34	76.6	0.85	950
EFS 480-CL(OP)/4500-SR1 ^[9]	020/240-SR1	0.80	5.08	9.14	15.34	76.6	0.85	950

NOTES

1. SET = Spring Ending Torque at 90° (end to close for CL - end to open for OP).
2. SST = Spring Starting Torque at 0° (start to close for CL - start to open for OP).
3. MST = Electric Mode Starting Torque at 90° (start to open for CL - start to close for OP).
4. MET = Electric Mode Ending Torque at 0° (end to open for CL - end to close for OP).
5. ET = Time for stroke with electric motor at 50Hz; multiply by 0.833 for 60Hz supply.
6. FST = Fail-Safe adjustable Time.
7. The max. set actuator output torque is referred to the open/close manoeuvre done with the electric motor set at 40% and the spring.
8. Under no circumstances should the motor set torque of 40% in the closing/opening direction be changed or the torque by-pass be removed.
9. Asynchronous motors with DELTA connections.
10. Inom - Actuator nominal current (at 40% set output torque) according to ISO 12590.
11. Imax - Actuator current at max. torque (100% set output torque) according to ISO 12590.
12. Icc - Actuator locked rotor current (current measured with motor energized and output drive locked) according to ISO 12590.
13. Absorbed power at nominal conditions (Watt).

EFS 2000 ELECTRIC ACTUATORS

PERFORMANCE SINGLE PHASE SUPPLY 230 V / 50 Hz - SPRING TO CLOSE (CL) OR SPRING TO OPEN (OP)

ON/OFF S2-15', 60 STARTS/hr OR INCHING S2-30', 200 STARTS/hr

EFS Model	SET (Nm/lbf-ft) ^[1]	SST (Nm/lbf-ft) ^[2]	MST (Nm/lbf-ft) ^[3]	MET (Nm/lbf-ft) ^[4]	'ET (50Hz) sec/90° ^[5]	FST (sec/90°) ^[6]	Max. set actuator output torque (Nm/lbf-ft) ^[7,8]
EFS 10-CL(OP)/93-SR1 ^[9]	93/69	130/96	150/111	110/82	30 to 63	2 to 20	384/283
EFS 20-CL(OP)/225-SR1 ^[9]	225/166	300/222	350/259	275/203	22 to 84	2 to 20	602/444
EFS 40-CL(OP)/450-SR1 ^[9]	450/332	610/450	680/502	520/384	44 to 169	3 to 30	1206/890
EFS 80-CL(OP)/900-SR1 ^[9]	850/627	1150/849	1250/922	900/664	44 to 169	3 to 30	2091/1543
EFS 160-CL(OP)/1800-SR1 ^[9]	1800/1328	2800/2066	2800/2066	1800/1328	105 to 402	3 to 30	4791/3534
EFS 320-CL(OP)/3600-SR1 ^[9]	3600/2656	5400/3983	5400/3982	3600/2655	36 to 208	3 to 30	8685/6241
EFS 480-CL(OP)/4500-SR1 ^[9]	4500/3319	7800/5753	5800/4277	3600/2655	36 to 208	3 to 30	11085/8176

EFS Model	ICON model	Motor power (KW)	Motor nominal current (Inom) ^[10]	Motor max. current (Imax) ^[11]	Locked rotor current (Icc) ^[12]	'Eff. % nom'	Power factor	Absorbed power (Watt) ^[13]
EFS 10-CL(OP)/93-SR1 ^[9]	010/30-SR1	0.106	1.10	1.80	4.00	46.0	0.91	230
EFS 20-CL(OP)/225-SR1 ^[9]	010/90-SR1	0.184	3.20	5.50	11.50	27.8	0.90	662
EFS 40-CL(OP)/450-SR1 ^[9]	010/90-SR1	0.184	3.20	5.50	11.50	27.8	0.90	662
EFS 80-CL(OP)/900-SR1 ^[9]	010/110-SR1	0.184	3.20	5.50	11.50	27.8	0.90	662
EFS 160-CL(OP)/1800-SR1 ^[9]	010/110-SR1	0.184	3.20	5.50	11.50	27.8	0.90	662
EFS 320-CL(OP)/3600-SR1 ^[9]	020/240-SR1	0.80	5.08	9.14	15.34	76.6	0.85	950
EFS 480-CL(OP)/4500-SR1 ^[9]	020/240-SR1	0.80	5.08	9.14	15.34	76.6	0.85	950

NOTES

1. SET = Spring Ending Torque at 90° (end to close for CL - end to open for OP).
2. SST = Spring Starting Torque at 0° (start to close for CL - start to open for OP).
3. MST = Electric Mode Starting Torque at 90° (start to open for CL - start to close for OP).
4. MET = Electric Mode Ending Torque at 0° (end to open for CL - end to close for OP).
5. ET = Time for stroke with electric motor at 50Hz; multiply by 0.833 for 60Hz supply.
6. FST = Fail-Safe adjustable Time.
7. The max. set actuator output torque is referred to the open/close manoeuvre done with the electric motor set at 40% and the spring.
8. Under no circumstances should the motor set torque of 40% in the closing/opening direction be changed or the torque by-pass be removed.
9. Asynchronous motors with DELTA connections.
10. Inom - Actuator nominal current (at 40% set output torque) according to ISO 12590.
11. Imax - Actuator current at max. torque (100% set output torque) according to ISO 12590.
12. Icc - Actuator locked rotor current (current measured with motor energized and output drive locked) according to ISO 12590.
13. Absorbed power at nominal conditions (Watt).

EFS 2000 ELECTRIC ACTUATORS

PERFORMANCE SINGLE PHASE SUPPLY 240 V / 50 Hz - SPRING TO CLOSE (CL) OR SPRING TO OPEN (OP)

ON/OFF S2-15', 60 STARTS/hr OR INCHING S2-30', 200 STARTS/hr

EFS Model	SET (Nm/lbf-ft) ^[11]	SST (Nm/lbf-ft) ^[2]	MST (Nm/lbf-ft) ^[3]	MET (Nm/lbf-ft) ^[4]	'ET (50Hz) sec/90° ^[5]	FST (sec/90°) ^[6]	Max. set actuator output torque (Nm/lbf-ft) ^[7,8]
EFS 10-CL(OP)/93-SR1 ^[9]	93/69	130/96	150/111	110/82	30 to 63	2 to 20	384/283
EFS 20-CL(OP)/225-SR1 ^[9]	225/166	300/222	350/259	275/203	22 to 84	2 to 20	602/444
EFS 40-CL(OP)/450-SR1 ^[9]	450/332	610/450	680/502	520/384	44 to 169	3 to 30	1206/890
EFS 80-CL(OP)/900-SR1 ^[9]	850/627	1150/849	1250/922	900/664	44 to 169	3 to 30	2091/1543
EFS 160-CL(OP)/1800-SR1 ^[9]	1800/1328	2800/2066	2800/2066	1800/1328	105 to 402	3 to 30	4791/3534
EFS 320-CL(OP)/3600-SR1 ^[9]	3600/2656	5400/3983	5400/3982	3600/2655	36 to 208	3 to 30	8685/6241
EFS 480-CL(OP)/4500-SR1 ^[9]	4500/3319	7800/5753	5800/4277	3600/2655	36 to 208	3 to 30	11085/8176

EFS Model	ICON model	Motor power (KW)	Motor nominal current (Inom) ^[10]	Motor max. current (Imax) ^[11]	Locked rotor current (Icc) ^[12]	'Eff. % nom'	Power factor	Absorbed power (Watt) ^[13]
EFS 10-CL(OP)/93-SR1 ^[9]	010/30-SR1	0.127	1.27	2.07	4.60	46.0	0.91	276
EFS 20-CL(OP)/225-SR1 ^[9]	010/90-SR1	0.221	3.68	6.33	13.23	27.8	0.90	795
EFS 40-CL(OP)/450-SR1 ^[9]	010/90-SR1	0.221	3.68	6.33	13.23	27.8	0.90	795
EFS 80-CL(OP)/900-SR1 ^[9]	010/110-SR1	0.221	3.68	6.33	13.23	27.8	0.90	795
EFS 160-CL(OP)/1800-SR1 ^[9]	010/110-SR1	0.221	3.68	6.33	13.23	27.8	0.90	795
EFS 320-CL(OP)/3600-SR1 ^[9]	020/240-SR1	0.80	5.08	9.14	15.34	76.6	0.85	950
EFS 480-CL(OP)/4500-SR1 ^[9]	020/240-SR1	0.80	5.08	9.14	15.34	76.6	0.85	950

NOTES

1. SET = Spring Ending Torque at 90° (end to close for CL - end to open for OP).
2. SST = Spring Starting Torque at 0° (start to close for CL - start to open for OP).
3. MST = Electric Mode Starting Torque at 90° (start to open for CL - start to close for OP).
4. MET = Electric Mode Ending Torque at 0° (end to open for CL - end to close for OP).
5. ET = Time for stroke with electric motor at 50Hz; multiply by 0.833 for 60Hz supply.
6. FST = Fail-Safe adjustable Time.
7. The max. set actuator output torque is referred to the open/close manoeuvre done with the electric motor set at 40% and the spring.
8. Under no circumstances should the motor set torque of 40% in the closing/opening direction be changed or the torque by-pass be removed.
9. Asynchronous motors with DELTA connections.
10. Inom - Actuator nominal current (at 40% set output torque) according to ISO 12590.
11. Imax - Actuator current at max. torque (100% set output torque) according to ISO 12590.
12. Icc - Actuator locked rotor current (current measured with motor energized and output drive locked) according to ISO 12590.
13. Absorbed power at nominal conditions (Watt).

EFS 2000 ELECTRIC ACTUATORS

PERFORMANCE THREE PHASE SUPPLY 400 V / 50 Hz - SPRING TO CLOSE (CL) OR SPRING TO OPEN (OP)

ON/OFF S2-15', 60 STARTS/hr OR INCHING S2-30', 200 STARTS/hr MODELS EFS 10 TO EFS 80

EFS Model	SET (Nm/lbf-ft) ^[1]	SST (Nm/lbf-ft) ^[2]	MST (Nm/lbf-ft) ^[3]	MET (Nm/lbf-ft) ^[4]	'ET (50Hz) sec/90° ^[5]	FST (sec/90°) ^[6]	Max. set actuator output torque (Nm/lbf-ft) ^[7,8]
EFS 10-CL(OP)/93-41	93/69	130/96	150/111	110/82	41	2 to 20	260/191
EFS 10-CL(OP)/93-21	93/69	130/96	150/111	110/82	21	2 to 20	295/217
EFS 10-CL(OP)/93-14	93/69	130/96	150/111	110/82	14	2 to 20	295/217
EFS 10-CL(OP)/93-7	93/69	130/96	150/111	110/82	7	2 to 20	295/217
EFS 20-CL(OP)/225-41	225/166	300/222	350/259	275/203	41	2 to 20	658/485
EFS 20-CL(OP)/225-21	225/166	300/222	350/259	275/203	21	2 to 20	578/426
EFS 20-CL(OP)/225-14	225/166	300/222	350/259	275/203	14	2 to 20	667/491
EFS 20-CL(OP)/225-7	225/166	300/222	350/259	275/203	7	2 to 20	575/424
EFS 40-CL(OP)/450-83	450/332	610/450	680/501	520/383	83	3 to 30	1253/924
EFS 40-CL(OP)/450-41	450/332	610/450	680/501	520/383	41	3 to 30	1110/818
EFS 40-CL(OP)/450-28	450/332	610/450	680/501	520/383	28	3 to 30	1270/936
EFS 40-CL(OP)/450-14	450/332	610/450	680/501	520/383	14	3 to 30	1105/815
EFS 80-CL(OP)/900-83	850/627	1150/849	1250/921	900/663	83	3 to 30	1793/1323
EFS 80-CL(OP)/900-55*	850/627	1150/849	1250/921	900/663	55	3 to 30	2090/1542
EFS 80-CL(OP)/900-28	850/627	1150/849	1250/921	900/663	28	3 to 30	2090/1541
EFS 80-CL(OP)/900-14	850/627	1150/849	1250/921	900/663	14	3 to 30	2103/1551

EFS Model	ICON model	Motor power (KW)	Motor RPM	Motor nominal current (Inom) ^[9]	Motor max. current (Imax) ^[10]	Locked rotor current (Icc) ^[11]	'Eff. % nom'	Power factor	Absorbed power (Watt) ^[12]
EFS 10-CL(OP)/93-41	010/25-9	0.030	475	0.47	0.52	0.70	20.0	0.46	150
EFS 10-CL(OP)/93-21	010/25-18	0.140	950	0.97	1.32	2.90	45.3	0.46	309
EFS 10-CL(OP)/93-14	010/25-27	0.280	1440	1.10	1.71	4.75	65.6	0.56	427
EFS 10-CL(OP)/93-7	010/25-54	0.420	2880	1.25	2.36	6.90	68.3	0.71	615
EFS 20-CL(OP)/225-41	010/50-9	0.070	480	1.60	1.85	2.50	14.7	0.43	477
EFS 20-CL(OP)/225-21	010/50-18	0.140	950	0.97	1.32	2.90	45.3	0.46	309
EFS 20-CL(OP)/225-14	010/50-27	0.280	1440	1.10	1.71	4.75	65.6	0.56	427
EFS 20-CL(OP)/225-7	010/50-54	0.420	2880	1.25	2.36	6.90	68.3	0.71	615
EFS 40-CL(OP)/450-83	010/60-9	0.070	480	1.60	1.85	2.50	14.7	0.43	477
EFS 40-CL(OP)/450-41	010/60-18	0.140	950	0.97	1.32	2.90	45.3	0.46	309
EFS 40-CL(OP)/450-28	010/60-27	0.280	1440	1.10	1.71	4.75	65.6	0.56	427
EFS 40-CL(OP)/450-14	010/60-54	0.420	2880	1.25	2.36	6.90	68.3	0.71	615
EFS 80-CL(OP)/900-83	010/110-9	0.070	480	1.60	1.85	2.50	14.7	0.43	477
EFS 80-CL(OP)/900-55*	010/110-14	0.185	715	1.90	2.26	4.40	34.3	0.41	540
EFS 80-CL(OP)/900-28	010/110-27	0.365	1450	1.90	2.63	7.80	59.0	0.47	619
EFS 80-CL(OP)/900-14	010/110-54	0.740	2900	2.35	4.76	13.00	75.8	0.60	977

NOTES

1. SET = Spring Ending Torque at 90° (end to close for CL - end to open for OP).
 2. SST = Spring Starting Torque at 0° (start to close for CL - start to open for OP).
 3. MST = Electric Mode Starting Torque at 90° (start to open for CL - start to close for OP).
 4. MET = Electric Mode Ending Torque at 0° (end to open for CL - end to close for OP).
 5. ET = Time for stroke with electric motor at 50Hz; multiply by 0.833 for 60Hz supply.
 6. FST = Fail-Safe adjustable Time.
 7. The max. set actuator output torque is referred to the open/close manoeuvre done with the electric motor set at 40% and the spring.
 8. Under no circumstances should the motor set torque of 40% in the closing/opening direction be changed or the torque by-pass be removed.
 9. Inom - Actuator nominal current (at 40% set output torque) according to ISO 12590.
 10. Imax - Actuator current at max. torque (100% set output torque) according to ISO 12590.
 11. Icc - Actuator locked rotor current (current measured with motor energized and output drive locked) according to ISO 12590.
 12. Absorbed power at nominal conditions (Watt).
- * Motor service limited to S2-10'.

EFS 2000 ELECTRIC ACTUATORS

PERFORMANCE THREE PHASE SUPPLY 400 V / 50 Hz - SPRING TO CLOSE (CL) OR SPRING TO OPEN (OP)

ON/OFF S2-15', 60 STARTS/hr OR INCHING S2-30', 200 STARTS/hr MODELS EFS 160 TO EFS 960

EFS Model	SET (Nm/lbf-ft) ^[1]	SST (Nm/lbf-ft) ^[2]	MST (Nm/lbf-ft) ^[3]	MET (Nm/lbf-ft) ^[4]	'ET (50Hz) sec/90 ^o ^[5]	FST (sec/90 ^o) ^[6]	Max. set actuator output torque (Nm/lbf-ft) ^[7,8]
EFS 160-CL(OP)/1800-197	1800/1328	2800/2066	2800/2065	1800/1327	197	3 to 30	4162/3069
EFS 160-CL(OP)/1800-131*	1800/1328	2800/2066	2800/2065	1800/1327	131	3 to 30	4790/3533
EFS 160-CL(OP)/1800-98	1800/1328	2800/2066	2800/2065	1800/1327	98	3 to 30	4536/3345
EFS 160-CL(OP)/1800-66	1800/1328	2800/2066	2800/2065	1800/1327	66	3 to 30	4789/3532
EFS 160-CL(OP)/1800-33	1800/1328	2800/2066	2800/2065	1800/1327	33	3 to 30	4816/3552
EFS 320-CL(OP)/3600-103	3600/2656	5400/3983	5400/3982	3600/2655	103	3 to 30	8687/6407
EFS 320-CL(OP)/3600-69	3600/2656	5400/3983	5400/3982	3600/2655	69	3 to 30	8685/6405
EFS 320-CL(OP)/3600-34	3600/2656	5400/3983	5400/3982	3600/2655	34	3 to 30	8462/6241
EFS 480-CL(OP)/4500-103	4500/3319	7800/5753	5800/4277	3600/2655	103	3 to 30	11087/8177
EFS 480-CL(OP)/4500-69	4500/3319	7800/5753	5800/4277	3600/2655	69	3 to 30	11085/8176
EFS 480-CL(OP)/4500-34	4500/3319	7800/5753	5800/4277	3600/2655	34	3 to 30	10862/8011
EFS 960-CL(OP)/9000-136**	9000/6638	18000/13276	25500/18807	12500/9219	136	5 to 45	**
EFS 960-CL(OP)/9000-91**	9000/6638	18000/13276	25500/18807	12500/9219	91	5 to 45	**
EFS 960-CL(OP)/9000-45**	9000/6638	18000/13276	25500/18807	12500/9219	45	5 to 45	**

EFS Model	ICON model	Motor power (KW)	Motor RPM	Motor nominal current (Inom) ^[9]	Motor max. current (Imax) ^[10]	Locked rotor current (Icc) ^[11]	'Eff. % nom'	Power factor	Absorbed power (Watt) ^[12]
EFS 160-CL(OP)/1800-197	010/110-9	0.070	480	1.60	1.85	2.50	14.7	0.43	477
EFS 160-CL(OP)/1800-131*	010/110-14	0.185	715	1.90	2.26	4.40	34.3	0.41	540
EFS 160-CL(OP)/1800-98	010/110-18	0.290	960	1.45	2.07	5.50	61.4	0.47	472
EFS 160-CL(OP)/1800-66	010/110-27	0.365	1450	1.90	2.63	7.80	59.0	0.47	619
EFS 160-CL(OP)/1800-33	010/110-54	0.740	2900	2.35	4.76	13.00	75.8	0.60	977
EFS 320-CL(OP)/3600-103	020/210-18	0.520	950	2.70	3.57	9.10	57.9	0.48	898
EFS 320-CL(OP)/3600-69	020/210-27	0.780	1430	2.80	4.48	12.50	68.1	0.59	1145
EFS 320-CL(OP)/3600-34	020/210-54	1.470	2900	3.90	6.92	21.00	85.0	0.64	1729
EFS 480-CL(OP)/4500-103	020/240-18	0.520	950	2.70	3.57	9.10	57.9	0.48	898
EFS 480-CL(OP)/4500-69	020/240-27	0.780	1430	2.80	4.48	12.50	68.1	0.59	1145
EFS 480-CL(OP)/4500-34	020/240-54	1.470	2900	3.90	6.92	21.00	85.0	0.64	1729
EFS 960-CL(OP)/9000-136**	030/400-18	0.520	950	2.70	3.57	9.10	57.9	0.48	898
EFS 960-CL(OP)/9000-91**	030/400-27	0.780	1430	2.80	4.48	12.50	68.1	0.59	1145
EFS 960-CL(OP)/9000-45**	030/400-54	1.470	2900	3.90	6.92	21.00	85.0	0.64	1729

NOTES

1. SET = Spring Ending Torque at 90° (end to close for CL - end to open for OP).
2. SST = Spring Starting Torque at 0° (start to close for CL - start to open for OP).
3. MST = Electric Mode Starting Torque at 90° (start to open for CL - start to close for OP).
4. MET = Electric Mode Ending Torque at 0° (end to open for CL - end to close for OP).
5. ET = Time for stroke with electric motor at 50Hz; multiply by 0.833 for 60Hz supply.
6. FST = Fail-Safe adjustable Time.
7. The max. set actuator output torque is referred to the open/close manoeuver done with the electric motor set at 40% and the spring.
8. Under no circumstances should the motor set torque of 40% in the closing/opening direction be changed or the torque by-pass be removed.
9. Inom - Actuator nominal current (at 40% set output torque) according to ISO 12590.
10. Imax - Actuator current at max. torque (100% set output torque) according to ISO 12590.
11. Icc - Actuator locked rotor current (current measured with motor energized and output drive locked) according to ISO 12590.
12. Absorbed power at nominal conditions (Watt).

* Motor service limited to S2-10'.

** For model EFS 960 please contact Biffi.

EFS 2000 ELECTRIC ACTUATORS

PERFORMANCE DC SUPPLY 24 V - SPRING TO CLOSE (CL) OR SPRING TO OPEN (OP)

ON/OFF S2-15', 60 STARTS/hr, OR INCHING S2-30', 200 STARTS/hr SERVICE

EFS Model	SET (Nm/lbf-ft) ^[1]	SST (Nm/lbf-ft) ^[2]	MST (Nm/lbf-ft) ^[3]	MET (Nm/lbf-ft) ^[4]	'ET (50Hz) sec/90° ^[5]	FST (sec/90°) ^[6]	Max. set actuator output torque (Nm/lbf-ft) ^[7,8]
EFS 10-CL(OP)/93-SR1 ^[9]	93/69	130/96	150/111	110/82	17 to 42	2 to 20	212/156
EFS 20-CL(OP)/225-SR1 ^[9]	225/166	300/222	350/259	275/203	17 to 42	2 to 20	495/365
EFS 40-CL(OP)/450-SR1 ^[9]	450/332	610/450	680/502	520/384	34 to 84	3 to 30	994/733
EFS 80-CL(OP)/900-SR1 ^[9]	850/627	1150/849	1250/922	900/664	34 to 84	3 to 30	1865/1375
EFS 160-CL(OP)/1800-SR1 ^[9]	1800/1328	2800/2066	2800/2066	1800/1328	80 to 201	3 to 30	4360/3215

EFS Model	ICON model	Motor power (KW)	Motor nominal current (Inom) ^[10]	Motor max. current (Imax) ^[11]	Locked rotor current (Icc) ^[12]	Power factor	Absorbed power (Watt) ^[13]
EFS 10-CL(OP)/93-SR1 ^[9]	010/30-SR1	0.400	19.00	19.40	125.00	0.88	456
EFS 20-CL(OP)/225-SR1 ^[9]	010/90-SR1	0.400	22.00	33.00	125.00	0.76	528
EFS 40-CL(OP)/450-SR1 ^[9]	010/90-SR1	0.400	22.00	33.00	125.00	0.76	528
EFS 80-CL(OP)/900-SR1 ^[9]	010/110-SR1	0.400	22.00	33.00	125.00	0.76	528
EFS 160-CL(OP)/1800-SR1 ^[9]	010/110-SR1	0.400	22.00	33.00	125.00	0.76	528

NOTES

1. SET = Spring Ending Torque at 90° (end to close for CL - end to open for OP).
2. SST = Spring Starting Torque at 0° (start to close for CL - start to open for OP).
3. MST = Electric Mode Starting Torque at 90° (start to open for CL - start to close for OP).
4. MET = Electric Mode Ending Torque at 0° (end to open for CL - end to close for OP).
5. ET = Time for stroke with electric motor at 50Hz; multiply by 0.833 for 60Hz supply.
6. FST = Fail-Safe adjustable Time.
7. The max. set actuator output torque is referred to the open/close manoeuvre done with the electric motor set at 40% and the spring.
8. Under no circumstances should the motor set torque of 40% in the closing/opening direction be changed or the torque by-pass be removed.
9. Permanent magnet motor with brushes.
10. Inom - Actuator nominal current (at 40% set output torque) according to ISO 12590.
11. Imax - Actuator current at max. torque (100% set output torque) according to ISO 12590.
12. Icc - Actuator locked rotor current (current measured with motor energized and output drive locked) according to ISO 12590.
13. Absorbed power at nominal conditions (Watt).

EFS 2000 ELECTRIC ACTUATORS

OVERALL DIMENSIONS - SPRING TO CLOSE

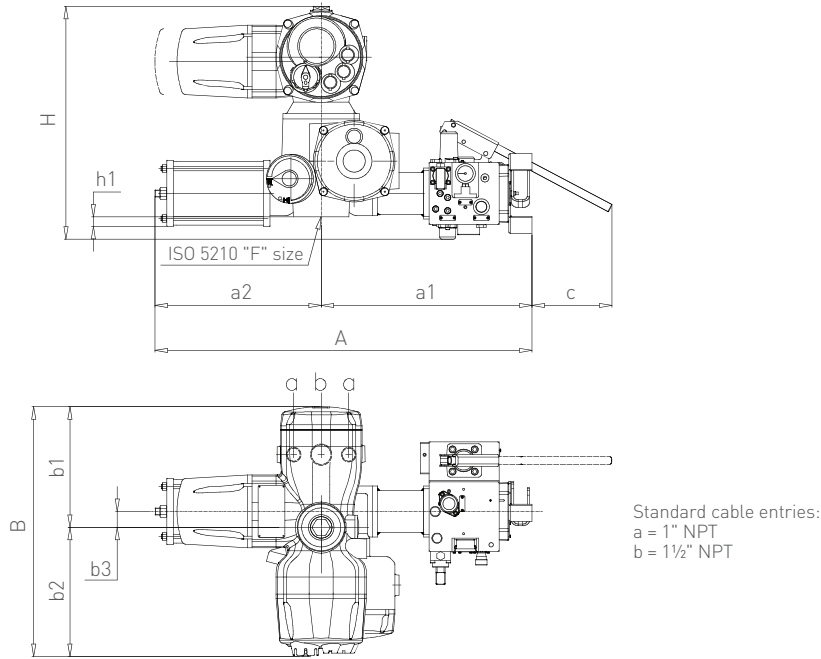

METRIC (mm)

Model	A	a1	a2	B	b1	b2	b3	C	H	h1	kg
EFS 10-CL	835	460	374	561	273	288	36	180	524	21	130
EFS 20-CL	829	454	374	561	273	288	36	180	524	24	170
EFS 40-CL	1076	539	536	561	273	288	65	180	512	27	177
EFS 80-CL	1070	535	536	561	273	288	65	180	534	55	160
EFS 160-CL	1413	665	748	639	287	352	125	180	575	50	290
EFS 320-CL	1741	796	945	734	349	385	164	180	794	61	468
EFS 480-CL	1741	796	945	734	349	385	164	180	794	85	480
EFS 960-CL	2151	974	1177	974	489	485	204	180	952	181	880

IMPERIAL (inches)

Model	A	a1	a2	B	b1	b2	b3	C	H	h1	lb
EFS 10-CL	32.9	18.1	14.7	22.1	10.7	11.3	1.4	7.09	20.6	0.8	287
EFS 20-CL	32.6	17.9	14.7	22.1	10.7	11.3	1.4	7.09	20.6	0.9	375
EFS 40-CL	42.4	21.2	21.1	22.1	10.7	11.3	2.6	7.09	20.2	1.1	390
EFS 80-CL	42.1	21.1	21.1	22.1	10.7	11.3	2.6	7.09	21.0	2.2	353
EFS 160-CL	55.6	26.2	29.4	25.2	11.3	13.9	4.9	7.09	22.6	2.0	639
EFS 320-CL	68.5	31.3	37.2	28.9	13.7	15.2	6.5	7.09	31.3	2.4	1032
EFS 480-CL	68.5	31.3	37.2	28.9	13.7	15.2	6.5	7.09	31.3	3.3	1058
EFS 960-CL	84.7	38.3	46.3	38.3	19.3	19.1	8.0	7.09	37.5	7.1	1940

EFS 2000 ELECTRIC ACTUATORS

OVERALL DIMENSIONS - SPRING TO OPEN

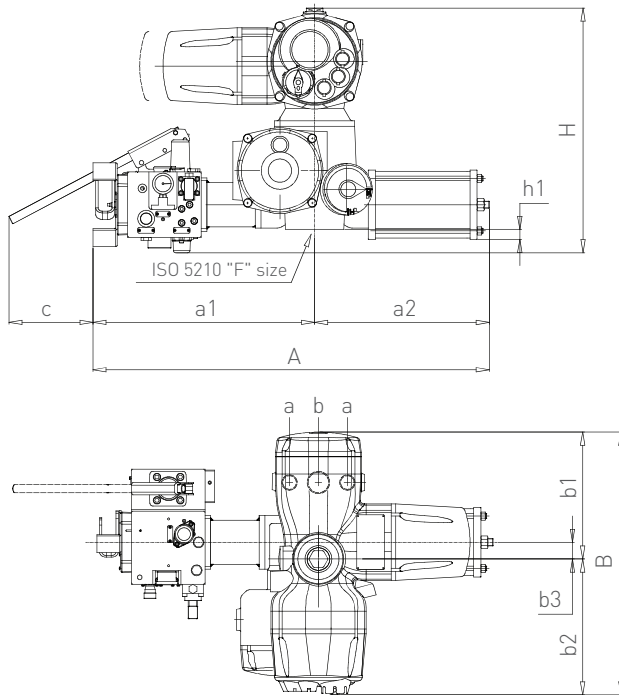

Standard cable entries:
 a = 1" NPT
 b = 1½" NPT

METRIC (mm)

Model	A	a1	a2	B	b1	b2	b3	C	H	h1	kg
EFS 10-OP	835	460	374	561	273	288	36	180	524	21	130
EFS 20-OP	829	454	374	561	273	288	36	180	524	24	170
EFS 40-OP	1076	539	536	561	273	288	65	180	512	27	177
EFS 80-OP	1070	535	536	561	273	288	65	180	534	55	160
EFS 160-OP	1413	665	748	639	287	352	125	180	575	50	290
EFS 320-OP	1741	796	945	734	349	385	164	180	794	61	468
EFS 480-OP	1741	796	945	734	349	385	164	180	794	85	480
EFS 960-OP	2151	974	1177	974	489	485	204	180	952	181	880

IMPERIAL (inches)

Model	A	a1	a2	B	b1	b2	b3	C	H	h1	lb
EFS 10-OP	32.9	18.1	14.7	22.1	10.7	11.3	1.4	7.09	20.6	0.8	287
EFS 20-OP	32.6	17.9	14.7	22.1	10.7	11.3	1.4	7.09	20.6	0.9	375
EFS 40-OP	42.4	21.2	21.1	22.1	10.7	11.3	2.6	7.09	20.2	1.1	390
EFS 80-OP	42.1	21.1	21.1	22.1	10.7	11.3	2.6	7.09	21.0	2.2	353
EFS 160-OP	55.6	26.2	29.4	25.2	11.3	13.9	4.9	7.09	22.6	2.0	639
EFS 320-OP	68.5	31.3	37.2	28.9	13.7	15.2	6.5	7.09	31.3	2.4	1032
EFS 480-OP	68.5	31.3	37.2	28.9	13.7	15.2	6.5	7.09	31.3	3.3	1058
EFS 960-OP	84.7	38.3	46.3	38.3	19.3	19.1	8.0	7.09	37.5	7.1	1940

EFS 2000 ELECTRIC ACTUATORS

OUTPUT DRIVE DIMENSIONS

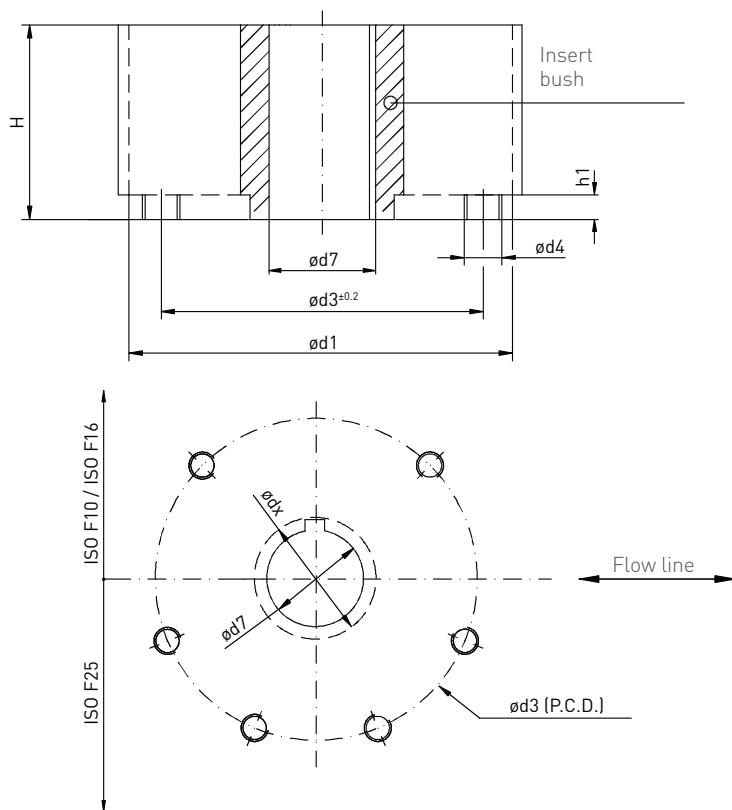

Model	ISO 5211	Ø d1	Ø d3	Ø d4	N	H min	h1	d7 Max. stem acceptance insert bush	
								Ø d7	Ø dx
EFS 10	F10	125	102	M10	4	50	20	25	35
EFS 20	F10	125	102	M10	4	50	20	25	35
EFS 40	F14	175	140	M16	4	89	25	42	51
EFS 80	F14	175	140	M16	4	89	25	42	51
EFS 160	F16	210	165	M20	4	105	30	65	76
EFS 320	F25	300	254	M16	8	130	25	90	104
EFS 480	F25	300	254	M16	8	130	25	90	104
EFS 960	F30	350	298	M20	8	165	30	103	120

NOTES

1. Insert bush supplied by Biffi with unmachined bore. Machining of bore upon request.
2. Fixing bolts or rods supplied by Biffi only on request, minimum material class required 8.8 UNI37409, ASTM A320-L7.
3. Any other coupling can be supplied on request.

EFS 2000 ELECTRIC ACTUATORS

BASE WIRING DIAGRAM

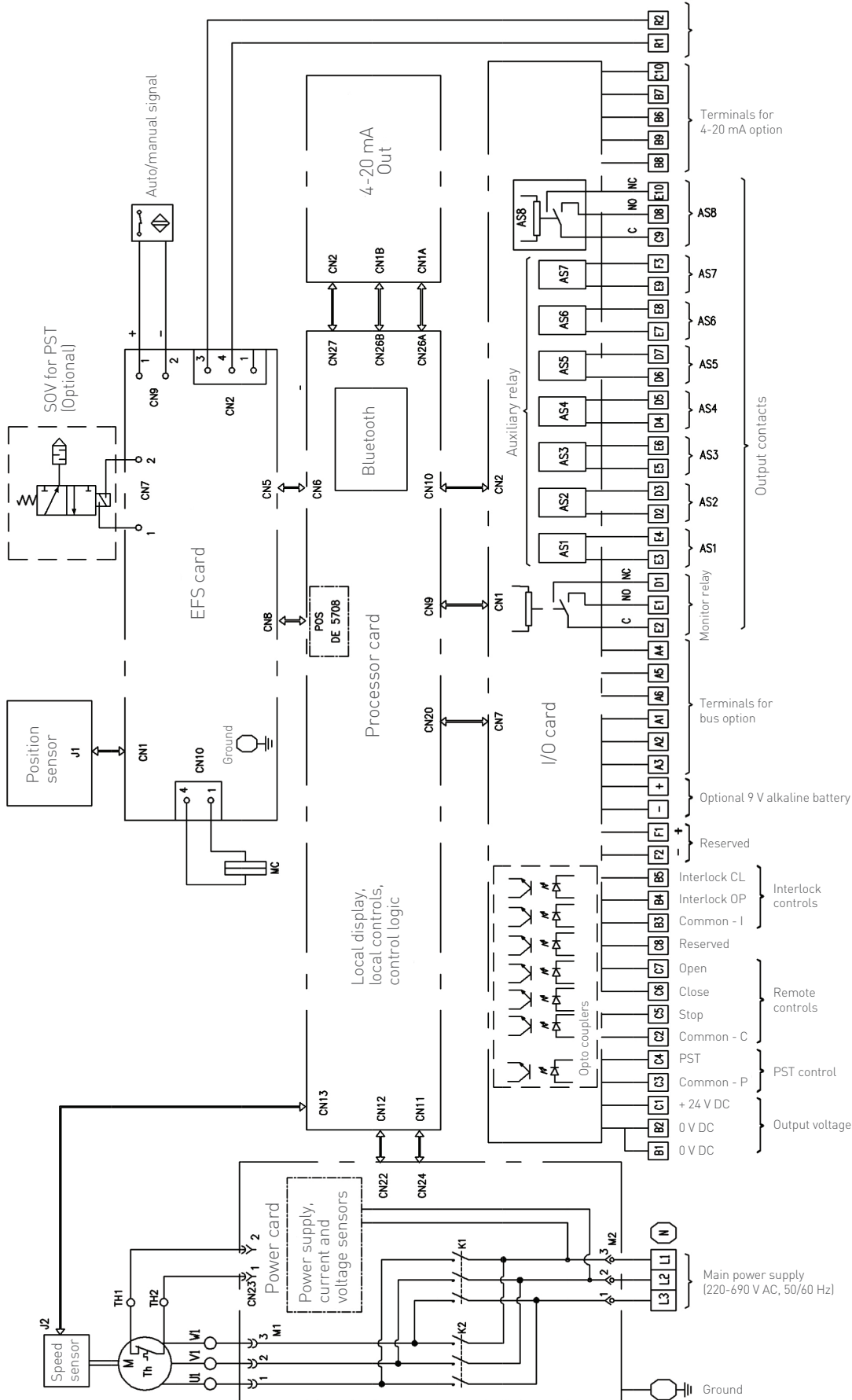

Default relay configuration: (may be modified - see instruction manual)

- AS1 = Open limit/make
- AS2 = Close limit/make
- AS3 = Selec. REMOTE pos. make
- AS4 = Overtorque/break
- AS5 = PST active/make
- AS6 = Position <10%/make
- AS7 = PST failed/make
- AS8 = Motor over temperature

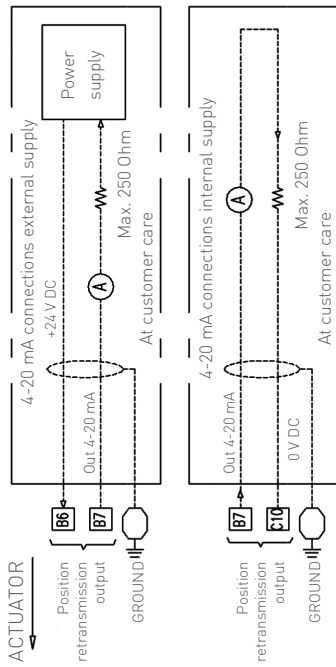

ESD2000 / FUNCTION DESCRIPTION:

- NORMAL CONDITIONS:**
1. Motor supply and ESD supply signal ON
The actuator is operable through remote push buttons when selector is in 'Remote' position
The actuator is operable through the local push buttons when selector is in
The actuator is not operable and it stays in the fail position when selector is in the OFF position

FAIL-SAFE CONDITIONS

- The actuator moves in Fail-Safe position when one of the following three conditions is present:
 - Three phase motor supply; OFF (condition to be configured)
 - ESD signal; OFF
 - Selector in OFF position
 Fail-Safe condition overrides any other commands which might be present when Fail-Safe condition occurs
When the above conditions are removed the actuator remains in Fail-Safe position until a local reset is activated
ESD note:
ESD: External supply 24 - 230 V DC or 24 - 230 V AC [50/60 Hz] min. power 40 W in rush 24 W maintained. With PST control min. power 50W

The factory default settings provide the electric command inhibited locally and remotely in the direction of the spring action. For modifications to the factory default settings please refer to the MAN 681 last revision.

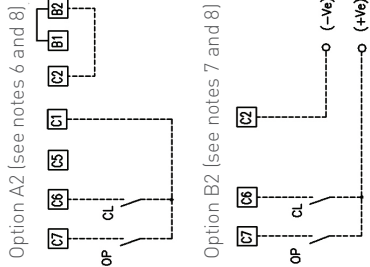
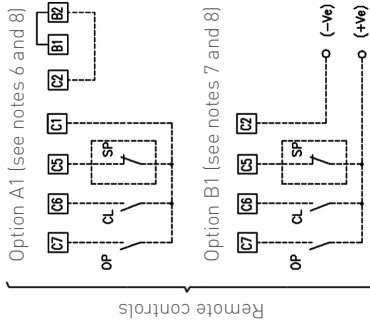

NOTES

- B1-B2 : Internally linked
- C1 : +24 V DC not regulated, max. 4 W
- Control signal levels:
Minimum 'ON' >20 V DC or 20 V AC [50/60 Hz]
Maximum 'ON' <125 V DC or 120 V AC [50/60 Hz]
Maximum 'OFF' <3 V DC or AC
Minimum signal duration >500 ms
Total current drawn for remote controls <25 mA
Total current drawn for ESD controls <15 mA
- Monitor relay:
Voltage free, change-over contact. Max. voltage 250 V AC or 30 V DC - max. current 5 A/min. voltage 5 V DC - min. current 10 mA
See instruction manual to view or configure the switching conditions of relay
-E2/D1 contact is closed when the configured condition occurs
- AS1, AS2, AS3, AS4, AS5: Voltage free contact. Max. voltage 250 V AC or 30 V DC - max. current 5 A / min. voltage 5 V DC - min. current 10 mA
Contact can be configured to make or break on condition. See Instruction manual to view or configure switching conditions of relays.
- A1, A2, A3 : Internal supply 24 V DC
- B1, B2, B3 : External supply 20-125 V DC or 20-120 V AC [50/60 Hz]
- Controls mode:
Option A1/B1 : 4 wires latched [SP configuration = BREAK]
Option A2/B2 : 3 wires push to run
 : 3 wires latched with instant reverse
Option A3/B3 : 2 wires open contact opens
 : 2 wires open contact closes
- SP contact: For options A1 and B1, SP contact can be configured as break to STOP or make to STOP

LEGENDA	
M	= Three phase motor
Th	= Motor thermostat
OP	= OPEN control
CL	= CLOSE control
SP	= STOP control
K1	= Opening/Closing contactor
K2	= Opening/Closing contactor
MC	= Magnetic Clutch

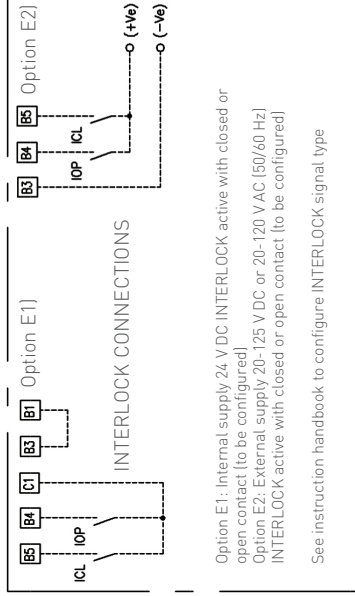

Biffi Italia s.r.l.
Strada Biffi 165
29017 Fiorenzuola d'Arda (PC)
Italy
T +39 0523 944 411

For complete list of sales and manufacturing sites, please visit
www.biffi.it or contact us at biffi_italia@biffi.it

VCTDS-02829-EN © 2024 Biffi. All rights reserved.

The contents of this publication are presented for informational purposes only, and while every effort has been made to ensure their accuracy, they are not to be construed as warranties or guarantees, express or implied, regarding the products or services described herein or their use or applicability. All sales are governed by our terms and conditions, which are available upon request. We reserve the right to modify or improve the designs or specifications of such products at any time without notice.

