

Overcome Your Most Demanding Automation Challenges



Biffi Actuators and Control Systems
Smart and Reliable Valve Automation





Maximize your plant's safety with the most advanced technology

With more than 60 years of experience, Biffi™ is a recognized market leader in delivering reliable and safe actuation and control solutions, with a proven expertise in solving the most demanding valve automation needs of oil & gas, power, processing, and water industry operators.

Our focus on technology provides increasingly smart systems to control and monitor valves, and allows us to offer both standard and custom made solutions, enabling our customers to maximize their plant's productivity, reducing downtime and ensuring the highest performance levels in a safe working environment.



Get top quality products, entirely engineered and manufactured in Italy. In-house and fully integrated design, manufacturing and testing facilities guarantee the highest quality standards for every Biffi product, which are individually tested for torque and performance to maximize their reliability and durability.



Your plant has one optimal actuation solution, and we help you achieve it.

Designed around your plant's requirements

Understanding and solving our customers' problems, while protecting plant assets, personnel and the environment with smarter, safer and more efficient operation, is our top priority.

Our team of actuation experts—with a unique cross-functional expertise in valve automation, safety applications, process control and digital communications—strive to be a global partner, effectively supporting every customer throughout the whole selection and decision-making process.

Rely on us, anytime and anywhere

Biffi's Lifecycle Services Program allows your plant to operate safely, consistently and economically, improving your asset reliability and preserving your investment.

Our dedicated Lifecycle Services network covers all geographical areas, ensuring quick and professional support. Our services include site walkdown and asset review, installation, commissioning, maintenance, troubleshooting and repair, STO (Shutdown, Turnaround, Outage) support, upgrade, replacement, retrofit, and spare parts management.

Furthermore, the Biffi School of Actuation supports our customers in optimizing their plant performance through dedicated training sessions for site personnel.

Rely on sophisticated technology

SIL capable products (IEC-61508 1-7:2010 SIL 2&3) provide exceptional performance in the most extreme operating conditions. Smart control and networking devices improve actuator capabilities with a wide range of bus communication protocols, position feedback, PST capabilities and more.



Don't compromise on product quality. In-house design, manufacturing and testing of every actuator component guarantee the highest quality standards for our trusted products.

Achieve top performance

Best-in-class valve control and automation solutions minimize plant shutdowns and maintenance costs, and optimize productivity.

Experience smooth integration and flexibility

Compliance with open standards allows networking and interoperability and reduces integration complexity.

Low Pressure Actuators



Robust, versatile, high performing actuators with fail safe capability

All low pressure actuators are available in double-acting and spring-return versions for any quarter-turn or linear valve.

- Scotch yoke actuators
- Heavy duty rack & pinion actuators
- Linear actuators
- Helical slot (see under compact actuators, page 13)

Scotch yoke actuators

ALGA-ALGAS

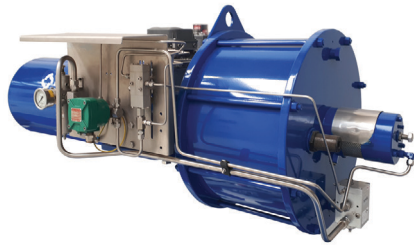

ALGA-ALGAS pneumatic scotch yoke actuators are suitable for quarter-turn valves up to the largest sizes, thanks to an efficient design and high break-out torque. The QA version with damper performs fail stroking in less than 1 second.

- Design pressure: 12 barg (174 psi)
- Double-acting torque: up to 750.000 Nm (6,630,000 lb-in.)
- Spring ending torque: up to 235.000 Nm (2,078,000 lb-in.)

MORIN S

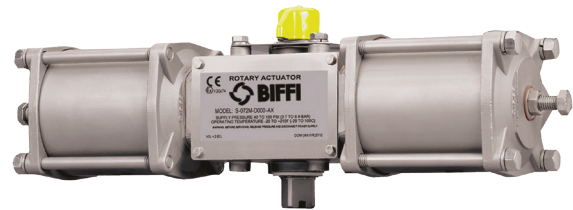

MORIN S scotch yoke actuators have a full stainless steel construction, providing maximum corrosion resistance under the harshest ambient conditions.

- Design pressure: 11 barg (160 psi)
- Double-acting torque: up to 26.900 Nm (238,000 lb-in.)
- Spring ending torque: up to 11.760 Nm (104,125 lb-in.)

FCBB and FCBA



FCBB and FCBA pneumatic scotch yoke actuators are compact, lightweight and economical scotch-yoke design actuators providing optimum torque curves for quarter-turn operation. The FCBB, with standard dual valve mounting interface, provides flexibility for installation in a fail-open or fail-closed application without the need of actuator disassembly.

The housing can be ductile iron or, if requested, with the low temperature carbon steel option.

- Design pressure: 12 barg (174 psi)
- Double-acting torque: up to 2.492 Nm (7,388 lb-in.)
- Spring ending torque: up to 1.182 Nm (22,055 lb-in.)

Heavy duty rack & pinion actuators

RPD-RPS



RPD-RPS rack & pinion actuators offer a reliable, easy and cost effective solution, providing maximum torque output with minimum supply pressure. The housing can be ductile iron or carbon steel; all other parts are in low temperature carbon steel as a minimum.

- Design pressure: 12 barg (174 psi)
- Double-acting torque: up to 3.700 Nm (32,700 lb-in.)
- Spring ending torque: up to 1.100 Nm (9,700 lb-in.)

Linear actuators

PLA-PLAS

PLA-PLAS linear actuators are suitable for any linear valve, with thrust and stroke available according to customer's requirements.

- Design pressure: 12 barg (174 psi)
- Double-acting thrust: up to 1.600.000 N (359,000 lb)
- Spring ending thrust: up to 555.000 N (124,800 lb)



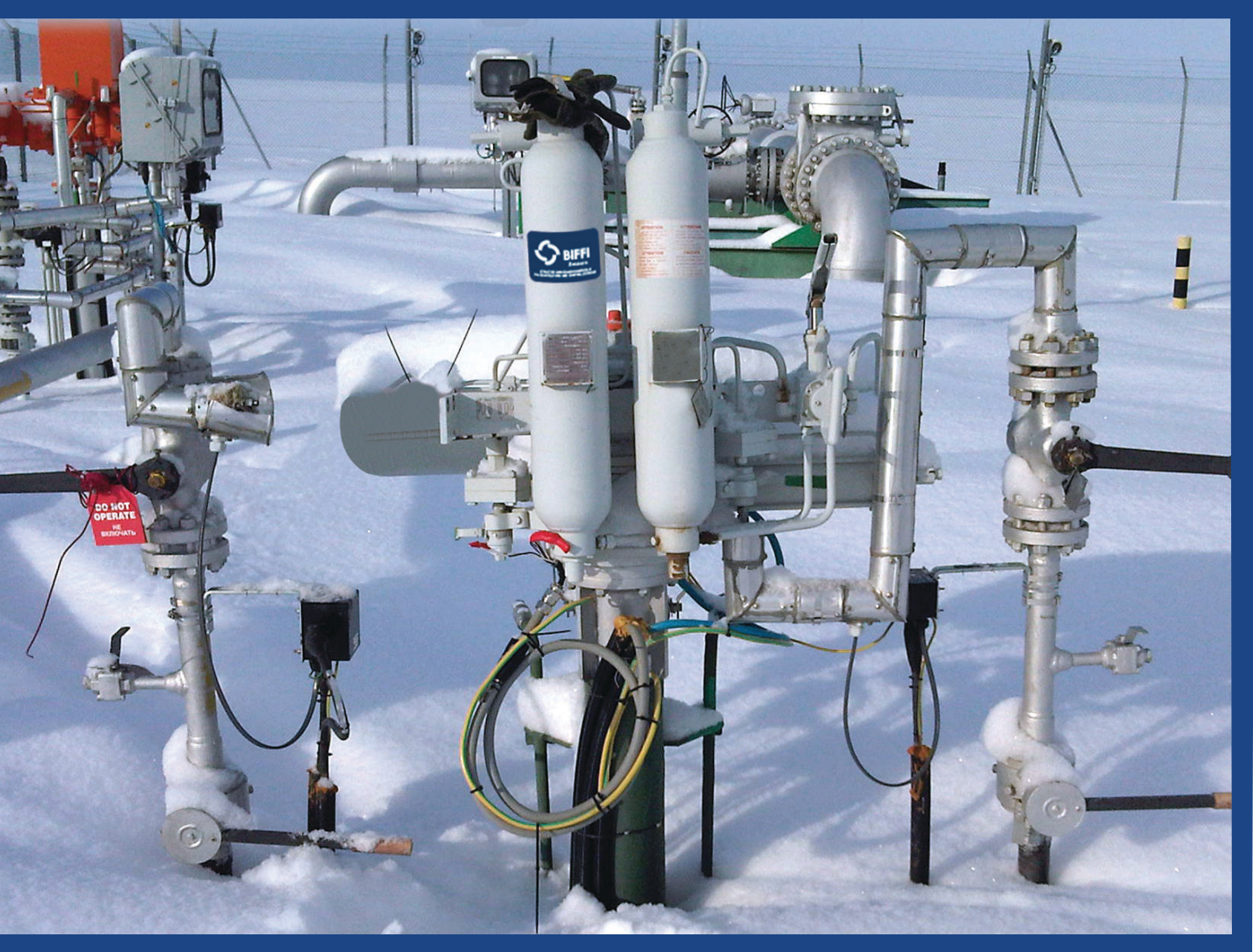

High Pressure Actuators

Proven in-field technology

Biffi has been a major supplier of pipeline/direct gas and gas-over-oil actuators for high pressure applications for over five decades, with many thousands of units providing reliable, effective service worldwide in the most remote locations, from the Siberian steppes to the Arabian deserts.

- Scotch yoke actuators
- Direct gas/gas over oil actuators
- Heavy duty rack & pinion actuators
- Linear actuators
- Helical slot (see under compact actuators, page 13)

Linear actuators

HLA and HLAS

HLA and HLAS hydraulic actuators are designed for on/off and modulating control of any linear valve, with thrust according to customer's requirements.

- Design pressure: 220 to 350 barg (3190 to 5076 psi)
- Double-acting thrust: up to 8.000.000 N (1,798,000 lb)
- Spring ending thrust: up to 350.000 N (78,000 lb)



Scotch yoke actuators

OLGA/OLGA-H and OLGAS/OLGAS-H

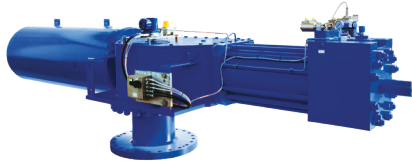

Efficient design and high break-out torque make **OLGA/OLGA-H and OLGAS/OLGAS-H hydraulic actuators** suitable for most quarter-turn valves and larger heavy-duty applications.

- Design pressure: 220 to 350 barg (3190 to 5076 psi)
- Double-acting torque: up to 1.000.000 Nm (8,850,745 lb-in.)
- Spring ending torque: up to 235.000 Nm (2,079,000 lb-in.)

Direct gas/gas over oil actuators

OLGAS/OLGAS-H



GIG/S and GPO gas powered actuators with fully integrated control systems combine high pressure components entirely designed by Biffi, including conventional or electronic line break monitoring systems, where requested.

- Design pressure: 100 barg (1,500 psi)
- Double-acting torque: up to 750.000 Nm (6,630,000 lb-in.)
- Spring ending torque: up to 235.000 Nm (2,079,000 lb-in.)

Heavy duty rack & pinion actuators



RPHD and RPHS

RPHD and RPHS hydraulic actuators are suitable for high pressure applications and on/off or modulating heavy duty service.

- Design pressure: up to 220 barg (3,190 psi)
- Double-acting torque: up to 2.600 Nm (23,000 lb-in.)
- Spring ending torque: up to 950 Nm (8,400 lb-in.)



Electro-hydraulic solutions

Smart and fast: double-acting and spring-return solutions when electrical power is the only available source

Both standard and smart electro-hydraulic solutions use a self-contained power unit to operate and control the actuators, allowing high torque, high speed modulating and/or fail-safe action when only electric power is available and reliability is crucial.

The standard version is for on/off ESD/HIPPS applications, while the smart version is designed for modulating ESD applications and provides alert, alarm, diagnostic and self-calibration features.

- Standard electro-hydraulic actuators
- Custom made electro-hydraulic actuators with accumulator
- Smart electro-hydraulic actuators

Configured smart electro-hydraulic actuators



EHO

A smart, self-contained, electro-hydraulic, quarter-turn valve actuator combining field-proven technologies, designed for reliable, critical shutdown applications.

- Operating pressure up to 350 barg (5076 psi)
- Wide range of single-phase, three-phase or DC power sources, also solar panels are available for areas without electrical power
- Spring ending torque up to 110.000 Nm (973,000 lb-in.)

Engineered electro-hydraulic actuators

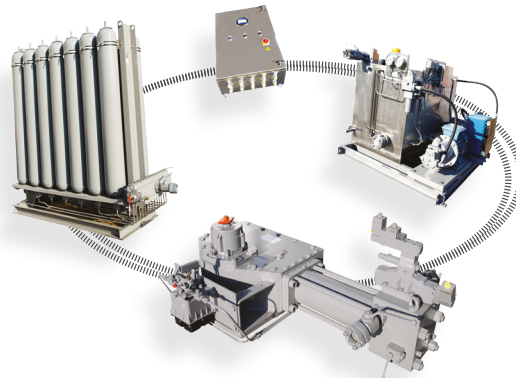

EHT and S-EHT

S-EHT is a self-contained system allowing high level diagnostics, digital and analog control through all major serial bus protocols, and wireless access via Bluetooth®.

It includes a high-pressure actuator with hydraulic motor pump system, suitable for quarter-turn and linear applications, equipped with dedicated electronic control unit.

- Design pressure: 220 to 345 barg (3,190 to 5,000 psi)
- Wide range of V AC or V DC power supplies available
- Single- and double-acting
- Includes hydraulic accumulators, redundancy or single electric motor pumps, switches and controls.
- Universal solution for all valve applications: on/off, with high speed fail action, position control, heavy duty modulation.
- Wide range of local and bus communication interfaces

Compact actuators

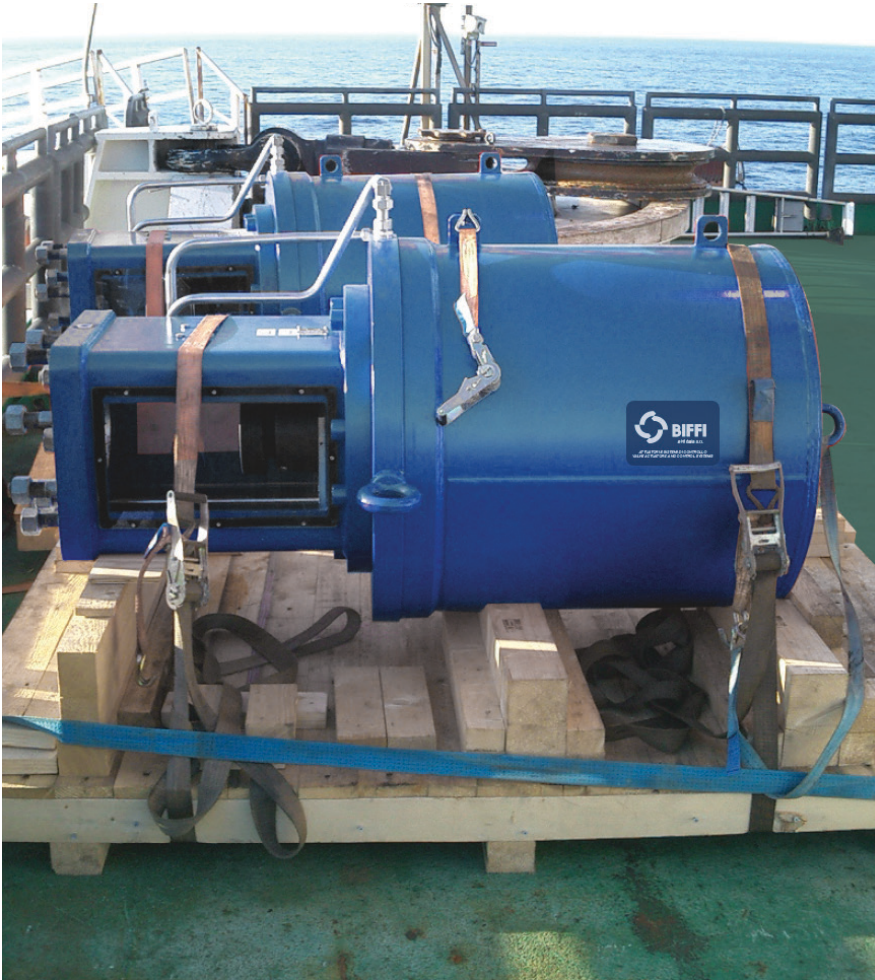

Reduced footprint, same performance

Biffi compact actuators are the ideal solution where space is limited but top performance is required, like offshore platforms, onshore terminals, tank farms, FPSOs, oil refineries and power plants. They are available single-acting for linear and quarter-turn applications, with the spring pack integrated into the cylinder.

- Compact quarter-turn pneumatic actuators
- Compact linear hydraulic actuators

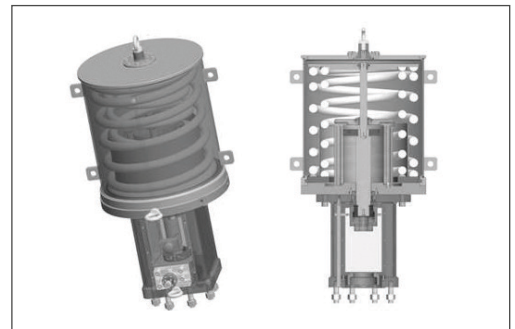
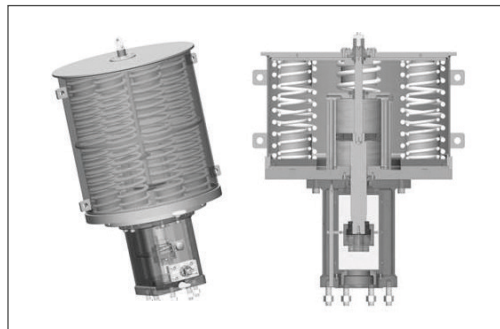

Compact quarter-turn pneumatic actuators



TPD-TPS

The **TPD-TPS quarter-turn actuator's** footprint is reduced, thanks to a unique helical slot design, which transforms the linear movement of the piston into a quarter-turn rotation, generating high breakout torques, and reducing both size and weight.

- Design pressure: 12 barg (174 psi)
- Double-acting torque: up to 300.000 Nm (2,665,000 lb-in.)
- Spring ending torque: up to 66.000 Nm (584,000 lb-in.)

Compact linear hydraulic actuators



HLAS-C

HLAS-C compact linear actuators, with hydraulic cylinder contained in the spring pack, are designed for on/off and modulating control of any linear valve, with thrust according to customer's requirement.

- Design pressure: up to 220 to 350 barg (3190 to 5076 psi)
- Double-acting thrust: up to 8.000.000 N (1,798,000 lb)
- Spring ending thrust: up to 350.000 N (78,000 lb)

Quick-acting actuators



The quickest actuation solution for maximum plant safety

This product line of highly engineered fail-safe pneumatic and hydraulic actuators enhances the safety of your plant. They feature integral quick exhaust valves (pneumatic) or high flow dump valves (hydraulic) and effective end-of-stroke shock absorbing systems to combine highest speed performance with maximum safety and reliability. Both pneumatic and hydraulic quick-acting actuators can be provided with modulating control circuits and partial stroke test (PST) capability. A quick-acting solution with or without damper is available for quarter-turn and linear solutions.

Quick-acting pneumatic, hydraulic, electro-hydraulic actuators



ALGAS-QA

ALGAS-QA are quick-acting spring-return pneumatic actuators with integral quick exhaust valves and end-of-stroke shock absorbing systems designed by Biffi.

- Design pressure: up to 12 barg (174 psi)
- Operating time: less than 1 s



OLGAS-QA

OLGAS-QA are quick-acting spring-return hydraulic and electro-hydraulic actuators with high flow rate manifold and cylinder, integral quick exhaust valves, and end-of-stroke damper systems, designed by Biffi.

- Design pressure: up to 250 barg (3600 psi)
- Operating time: less than 0.3 s

Valve Operating Systems (VOS)

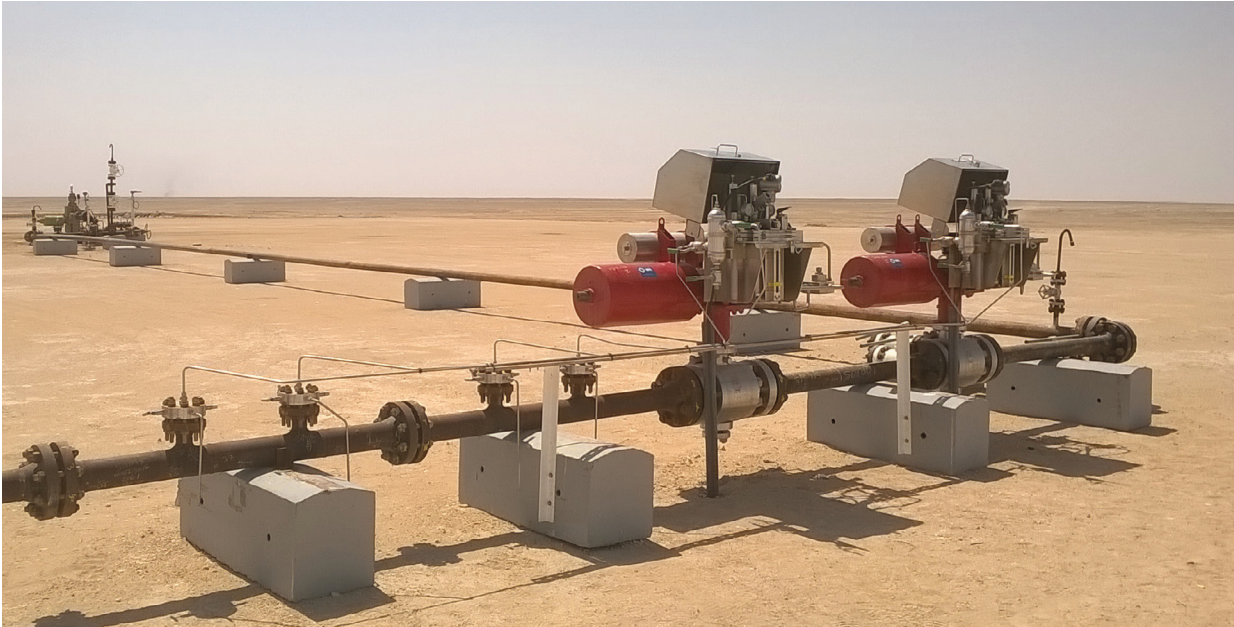

Fully customizable control systems for highest performance

Biffi's core expertise, collected across many decades, enables us to provide valve automation solutions with highly engineered systems for local or remote control of on/off or modulating actuators, via electric or pneumatic signals. These electromechanical control systems provide dependable "fail-safe" or "fail-steady" functionality in the event of an emergency, like electric or pneumatic supply failure, high temperature, or low or high pipeline pressure. Biffi automated solutions are SIL 3 capable and completely designed and manufactured in-house.

You can find more details regarding pneumatic components at the Biffi website.

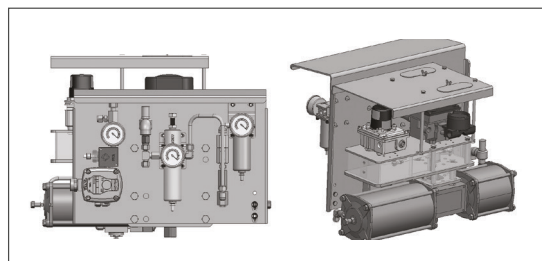
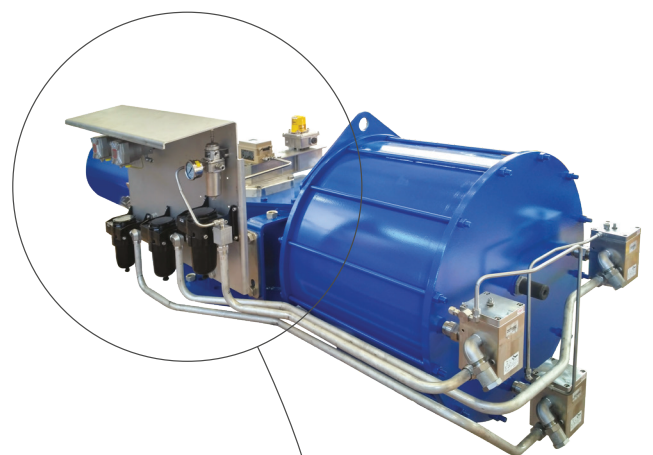

Electric actuators



Smart and fail-safe solutions for integrated systems

Biffi offers a wide range of smart electric actuators for quarter- and multi-turn applications. Shutdown capability and smart technology, to remotely control and operate valves, guarantee the highest safety in the event of an emergency.

- Multi-turn actuators
- Quarter-turn actuators
- Electric fail-safe actuators



Multi-turn actuators

ICON3000

Smart multi-turn actuator with advanced communication technology, data management and reliable operation.

- Torque: 30 to 1.440 Nm (265 to 12,745 lb-in.)
- Voltages: 24 V DC to 690 V AC (3 phase)
- Temperature range : -60 °C to +85 °C (-76 °F to +185 °F)
- Speed range: 12 to 173 RPM
- A-Manager or DCMLink diagnostic software compatibility



Electric fail-safe actuators

EFS 3000

Designed for fail open/closed operations in emergency conditions. Compliant with all open bus protocols, with PST capability.

SIL 3 rated, suitable for ROSOV (remote operated shut-off valves).

- Spring operation: starting torque up to 18000 Nm (159,000 lb-in.), ending torque up to 9000 Nm (80,000 lb-in.)
- Voltage: 3 PH from 208 to 690 V 50/60 Hz
1 PH from 110 to 240 V 50/60 Hz
24 V DC
- Temperature range: up to -20 °C to +85 °C (-4 °F to +185 °F)
- Safety integrity level (61508-1:2010) - SIL 3

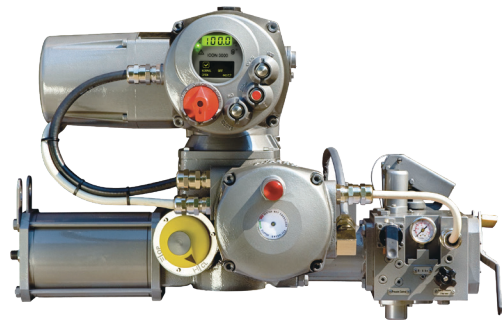

Quarter-turn actuators

F01 3000

Intelligent quarter-turn actuator featuring advanced operation, control, setting and maintenance.

- Torque: up to 600 Nm (5,310 lb-in.)
- Time/90° stroke: from 5 up to 60 s
- Temperature range: -20 °C to +85 °C (-4 °F to + 185 °F)



Control and networking solutions



Keep your plant always under control with the most advanced and reliable technology

Biffi networking solutions are based on intelligent actuators and smart devices for detection and monitoring, enabling diagnostic functions, while valves are online and in service. Biffi master stations allow remote control of the actuators through the most common bus protocols, guaranteeing maximum plant reliability even in the most severe operating conditions.

- Electronic Control Units
- Integrated Valve Monitoring System
- Electronic line break systems
- Diagnostic communication

Electronic Control Unit



ECU1000

This component of the integral control panel provides control and diagnostics functions for any Biffi electro-hydraulic actuator like:

- Control on/off and positioning of modulating actuators (heavy duty, low drain-heavy duty, stepping)
- Control of integral HPU with single or dual pump with automatic switch
- PST and interlock function
- Outputs to control on/off solenoid operated valves (SOVs), servo valves, proportional valves, or electrical motors (hardwired or bus remotely controlled)

Electronic Line Break System



ELBS20

ELBS20 is a smart device for pipeline pressure monitoring. In case of failure, it sends a command to the actuator to stroke the valve to the defined fail-safe position.

- Monitoring of five safety critical parameters: pressure drop rate; pressure decrease and/or increase against reference value, low and/or high limit exceeded
- Modbus® RTU (RS485), Bluetooth, RS485 point-to-point, RS232, HART®
- Special OLED display to operate down to $-40\text{ }^{\circ}\text{C}$ ($-40\text{ }^{\circ}\text{F}$)

Integrated Valve Monitoring System



IMVS2

IMVS2 is an integrated valve monitoring system for high- or low-pressure applications with position monitoring and on-line diagnostic capability and testing of all components in the Safety Instrumented function, including multiple solenoid valves.

- Hydraulic or pneumatic PST device
- Asset Management software as a standard
- For low- and high-pressure applications (up to 400 barg 5,800 psi)
- HART 7 and Modbus hydraulic bus interfaces
- Bluetooth, RS232 and RS485 interface
- On-board push button for local setting and commands
- 3 digital inputs and 6 digital outputs
- OLED graphic display able to operate down to $-40\text{ }^{\circ}\text{C}$ ($-40\text{ }^{\circ}\text{F}$)

Field Gateway



Master Station

Master Station is a highly reliable device, able to manage a huge number of actuators with a field loops capability, providing ultra fast communication speed. Levels of system redundancy and encrypted communications guarantee the highest data safety.

- Field protocol: LonWorks®, Modbus
- Fast communication to the field

Biffi is a reliable partner for complete actuation solutions



AMERICAS

19200 Northwest Freeway
Houston Texas 77065
USA
Phone: +1 281 477 4100
Houston.Inquiries@Emerson.com

EUROPE

Strada Biffi 165
Fiorenzuola d'Arda (PC) 29017
Italy
Phone: +39 0523 944 411
Biffisales@Emerson.com

MIDDLE EAST & AFRICA

Emerson FZE
P.O. Box 17033
JAFZA South Zone
Dubai, UAE
Phone: +971 4811 8100
actuator.enquiries@emerson.com

INDIA

Plot No. C1 Talegaon MIDC Phase 2
Mindewadi Taluka Maval
Pune 27 Maharashtra 410506
India
actuator.enquiries@emerson.com

ASIA PACIFIC

No. 9 Gul Road #01-02
629361
Singapore
AP.Inquiries@emerson.com

Biffi Italia S.r.L.

Strada Biffi, 165 - 29017 Fiorenzuola d'Arda (PC) - ITALY
Ph: +39 (0)523 944 411
E-mail: Biffisales@Emerson.com

Biffi reserves the right to change product designs
and specifications without notice.
FCBR-20191-EN Rev B 10-24



www.linkedin.com/company/biffi-italia-srl



www.youtube.com/user/BiffiItaliaSrl



www.biffi.it



THE HIGH-PERFORMANCE VALVE MOTION